

HAKKIMIZDA

Marmara ve Ege bölgesinde yaygın satış ağına sahip olan ASİSTAL ALÜMİNYUM, 1994 yılından bu yana hizmet vermektedir.

Fabrikamız Kırklareli Organize Sanayi bölgesi içinde yer almakta olup, 44 000 m² lik açık alan üzerinde 19 000 m² lik kapalı alana kuruludur. Son teknolojik gelişmeleri takip eden fabrikamızda 4 inç, 7 inç ve 8 inçlik 3 adet presimiz , eloksal tesisimiz, elektros-tatik toz boyama ünitemiz, ahşap transfer kaplama merkezimiz ile mekanik işleme merkezimiz yer almaktadır. Çevreye duyarlı tesisimizde 15m³/saat kapasiteli (360 m³/gün) kimyasal arıtma ünitemiz ile geri kullanılabilir su elde edilebilmektedir.

ASİSTAL ALÜMİNYUM, balkanlar başta olmak üzere, Avrupa, orta doğu, orta Amerika ülkeleri dahil 30 a yakın ülkeye ihracat yapmaktadır.

Ana satış mağazalarımız Çorlu, Tekirdağ, Edirne, İstanbul, İzmir ve Bulgaristan'ın başkenti Sofya olmak üzere hizmetlerimize devam etmekteyiz.

ABOUT US

Asistal Aluminum having a widespread selling network in the Marmara and Aegean regions, serves since 1994.

Our factory is in the Kırklareli organized industrial zone and established in a closed area of 19 000 m², on an open area of 44 000 m². In our factory, following the recent technological developments, there are 3 presses of 4 inches, 7 inches and 8 inches, eloxal facility, electrostatic powder painting unit, wooden transfer coating center, and mechanical processing center. In our facility, sensitive against the environment, reusable water can be obtained with the chemical treatment unit with a capacity of 15 m³/hour (360 m³/day).











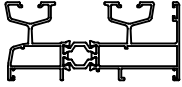

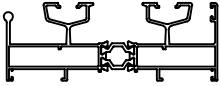

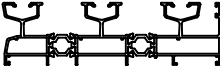

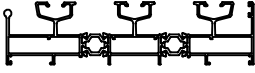

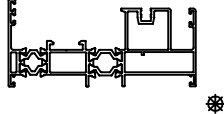

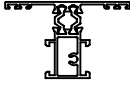
Asistal Aluminum exports near 30 countries, including European, the Middle Eastern, central America, especially to Balkans.

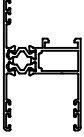
Our main sales stores are in Çorlu, Tekirdağ, Edirne, İstanbul, İzmir, and Sofia, the capital of Bulgaria and we continue our services.

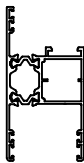
PROFİL VE AKSESUAR LİSTELERİ
PROFILE & ACCESSORIES LIST

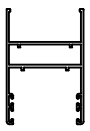
ALASIS
ASIS
ISIT

















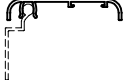

PROFİL LİSTESİ - PROFILES LIST

SL40T 01			SL40T 42		
KASA PROFİLİ FRAME PROFILE	AĞIRLIK / Weight 1,676 kg/mt		ADAPTÖR PROFİLİ ADAPTER PROFILE	AĞIRLIK / Weight 0,738 kg/mt	
SL40T 02			SL40 81		
KASA PROFİLİ FRAME PROFILE	AĞIRLIK / Weight 1,968 kg/mt		KASA KAPAK PROFİLİ FRAME COVER PROFILE	AĞIRLIK / Weight 0,572 kg/mt	
SL40T 03			SL40 82		
3 LÜ KASA PROFİLİ FRAME PROFILE	AĞIRLIK / Weight 2,569 kg/mt		KASA KAPAK PROFİLİ FRAME COVER PROFILE	AĞIRLIK / Weight 0,588 kg/mt	
SL40T 05			SL40 72		
3 LÜ KASA PROFİLİ FRAME PROFILE	AĞIRLIK / Weight 2,862 kg/mt		SABİT PANJUR LAMELİ SHUTTER BLIND	AĞIRLIK / Weight 0,986 kg/mt	
SL40T 04			SL40 73		
SABİTLİ KASA PROFİLİ FRAME PROFILE	AĞIRLIK / Weight 1,933 kg/mt		LAMEL ADAPTÖR PROFİLİ SHUTTER ADAPTER PROFILE	AĞIRLIK / Weight 0,245 kg/mt	
SL40T 21			LS60 71		
ORTA KAYIT PROFİLİ TRANSOM-MULLION PROFILE	AĞIRLIK / Weight 1,004 kg/mt		KULP PROFİLİ HANDLE PROFILE	AĞIRLIK / Weight 2,050 kg/mt	
SL40T 11			LS60 72		
Jx cm ⁴ 10,64	Jy cm ⁴ 10,35		KULP KAPAK PROFİLİ HANDLE COVER PROFILE	AĞIRLIK / Weight 0,420 kg/mt	
SL40T 12			15-304216-09		
Jx cm ⁴ 12,43	Jy cm ⁴ 18,20		SİNEKLİK KANAT PROFİLİ FLYSCREEN SASH PROFILE	AĞIRLIK / Weight 0,352 kg/mt	
SL40 13			15-306317-11		
Jx cm ⁴ 9,43	Jy cm ⁴ 8,09		SİNEKLİK KANAT PROFİLİ FLYSCREEN SASH PROFILE	AĞIRLIK / Weight 0,561 kg/mt	
SL40T 41			SL40 64		
KENET PROFİLİ CENTRAL LOCKING PROFILE	AĞIRLIK / Weight 0,372 kg/mt		SİNEKLİK RAY PROFİLİ FLYSCREEN RAILE PROFILE	AĞIRLIK / Weight 0,478 kg/mt	

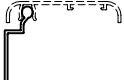
* Sipariş öncesi kalıp bilgisi kontrol edilmeli

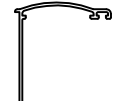
Profil ağırlıklarımız teorik olup; teslim anındaki tartımız geçerlidir.

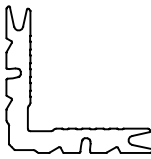
PROFİL LİSTESİ - PROFILES LIST

12-61			11-004		
RAY PROFİLİ RAILE PROFILE	AĞIRLIK / Weight 0,111 kg/mt		CAM ÇİTASI-4 mm GLAZING BEAD PROFILE	AĞIRLIK / Weight 0,181 kg/mt	
SL40 61			11-006		
"U" TİPİ RAY PROFİLİ RAILE PROFILE TYPE "U"	AĞIRLIK / Weight 0,148 kg/mt		CAM ÇİTASI-6 mm GLAZING BEAD PROFILE	AĞIRLIK / Weight 0,218 kg/mt	
SL40 62			11-010		
"V" TİPİ RAY PROFİLİ RAILE PROFILE TYPE "V"	AĞIRLIK / Weight 0,134 kg/mt		CAM ÇİTASI-10 mm GLAZING BEAD PROFILE	AĞIRLIK / Weight 0,233 kg/mt	
SL40 63			11-015		
RAY YUVA PROFİLİ RAILE GROOVE PROFILE	AĞIRLIK / Weight 0,132 kg/mt		CAM ÇİTASI-15 mm GLAZING BEAD PROFILE	AĞIRLIK / Weight 0,241 kg/mt	
SL40 35			11-017		
KANAT SABİTLEME PROFİLİ SASH FIXING PROFILE	AĞIRLIK / Weight 0,494 kg/mt		CAM ÇİTASI-17 mm GLAZING BEAD PROFILE	AĞIRLIK / Weight 0,250 kg/mt	
12-52			11-020		
PERVAZ PROFİLİ BORDER PROFILE	AĞIRLIK / Weight 0,279 kg/mt		CAM ÇİTASI-20 mm GLAZING BEAD PROFILE	AĞIRLIK / Weight 0,276 kg/mt	
12-53			11-022		
PERVAZ MONTAJ PROFİLİ BORDER FIXING PROFILE	AĞIRLIK / Weight 0,177 kg/mt		CAM ÇİTASI-22 mm GLAZING BEAD PROFILE	AĞIRLIK / Weight 0,282 kg/mt	
12-54			11-026		
PERVAZ PROFİLİ BORDER PROFILE	AĞIRLIK / Weight 0,326 kg/mt		CAM ÇİTASI-26 mm GLAZING BEAD PROFILE	AĞIRLIK / Weight 0,296 kg/mt	
10-010106-00					
KÖŞE TAKOZU-10,6 mm CORNER JOINT	AĞIRLIK / Weight 2,653 kg/mt				
10-010225-00					
KÖŞE TAKOZU-22,5 mm CORNER JOINT	AĞIRLIK / Weight 3,566 kg/mt				

* Sipariş öncesi kalıp bilgisi kontrol edilmeli

Profil ağırlıklarımız teorik olup; teslim anındaki tartımız geçerlidir.

AKSESUAR LİSTESİ - ACCESSORIES LIST





EP1-01			ASI-SFP 01		
DIŞ CAM FITİLİ - 2,5 mm OUTER GLAZING GASKET	KOLİ MİKTARI/Package 240 mt / 15 kg		HAVA KESİCİ - ALT/ÜST CENTRAL SEALING TOP / BOTTOM	KOLİ MİKTARI/Package Adet / Piece	
EP2-01			ASI-SFP 02		
İÇ CAM FITİLİ - 3 mm INNER GLAZING GASKET	KOLİ MİKTARI/Package 440 mt / 15 kg		HAVA KESİCİ - ALT/ÜST (SL40T 04 KASA İÇİN) CENTRAL SEALING TOP / BOTTOM - FOR SL40T 04	KOLİ MİKTARI/Package Adet / Piece	
EP2-02			SL40-PLU 01		
İÇ CAM FITİLİ - 4 mm INNER GLAZING GASKET	KOLİ MİKTARI/Package 300 mt / 15 kg		KASA KANAL PVC FRAME PVC CHANNEL	KOLİ MİKTARI/Package 6 mt / Adet	
EP2-03			SL40-PLU 02		
İÇ CAM FITİLİ - 5 mm INNER GLAZING GASKET	KOLİ MİKTARI/Package 250 mt / 15 kg		KASA KANAL PVC (SL40T 04 KASA İÇİN) FRAME PVC CHANNEL FOR SL40T 04	KOLİ MİKTARI/Package 6 mt / Adet	
SKF-01			SL40-STP		
SÜRME KAPATMA FITİLİ SLIDING GASKET	KOLİ MİKTARI/Package 265 mt / 15 kg		KANAT GÜVENLİK PLASTİĞİ ANTI-LIFT DEVICE	KOLİ MİKTARI/Package Adet / Piece	
KF 67-600			SL40-KNL		
FIRÇA FITİL - 6mm BRUSH GASKET	KOLİ MİKTARI/Package 1300 mt		İSPANYOLET KİLİTLEME PVC ADAPTÖR MULTI POINT LOCK ADAPTER	KOLİ MİKTARI/Package Adet / Piece	
KF 67-700			SL40-KLF		
FIRÇA FITİL - 7mm BRUSH GASKET	KOLİ MİKTARI/Package 1200 mt		RULMAN ADAPTÖR PVC ROLLER PVC ADAPTER	KOLİ MİKTARI/Package Adet / Piece	
ASI-5025			SL40-KP02		
SİNEKLİK FITİLİ FLYSCREEN GASKET	KOLİ MİKTARI/Package 100 mt		4 LÜ KANAT KİLİTLEME ADAPTÖR KAPAĞI MEETING STILE CAP	KOLİ MİKTARI/Package Adet / Piece	
SL40-PLZ 01			ASI-STP 03		
KENET PVC PROFİL (SL40T 11 İÇİN) FRAME PVC CHANNEL FOR SL40T 11	KOLİ MİKTARI/Package 6 mt / Adet		KANAT STOPER SASH STOPPER	KOLİ MİKTARI/Package Adet / Piece	
SL40-PLZ 02			SL40-KP01		
KENET PVC PROFİL (SL40T 12 İÇİN) FRAME PVC CHANNEL FOR SL40T 12	KOLİ MİKTARI/Package 6 mt / Adet		KENET KAPAĞI-ALT/ÜST INTERLOCK PROFILE CAP TOP / BOTTOM	KOLİ MİKTARI/Package Adet / Piece	

AKSESUAR LİSTESİ - ACCESSORIES LIST

MO60-19			ASI-SH 007B		
KOL PROFİL KAPAĞI HANDLE PROFILE CAP	KOLİ MİKTARI/Package alt-üst takım / set		ÇEKME HAVUZ KOL PULL EMBEDDED HANDLE	KOLİ MİKTARI/Package Adet / Piece	
ASI-SR 01			SL40-007K		
AYARLI TEKLİ RULMAN (V TİPİ RAY İÇİN) SINGLE SLIDING ROLLER FOR RAIL TYPE - V	KOLİ MİKTARI/Package Adet / Piece		HAVUZ KOL DİL-KARŞILIK (ASI-SH 007 ve 007A için) EMBEDDED HANDLE STRIKE HOOK FOR ASI-SH 007/007A	KOLİ MİKTARI/Package Takım / Set	
ASI-SR 02			ASI-SH 005		
AYARLI ÇİFTLİ RULMAN (V TİPİ RAY İÇİN) DOUBLE SLIDING ROLLER FOR RAIL TYPE - V	KOLİ MİKTARI/Package Adet / Piece		SÜRME ÇEKME KOL PULL HANDLE	KOLİ MİKTARI/Package Adet / Piece	
ASI-SR 02R			ASI-SH 006		
AYARLI ÇİFTLİ RULMAN (U TİPİ RAY İÇİN) DOUBLE SLIDING ROLLER FOR RAIL TYPE - U	KOLİ MİKTARI/Package Adet / Piece		SÜRME ÇEKME KOL PULL HANDLE	KOLİ MİKTARI/Package Adet / Piece	
ASI-BZ 5060			ASI-ISP15.1		
SİNEKLİK KANAT RULMAN FLYSCREEN SASH ROLLER	KOLİ MİKTARI/Package Adet / Piece		İSPANYOLET KİLİTLEME (600mm) MULTI POINT LOCK	KOLİ MİKTARI/Package Adet / Piece	
ASI-SH 001			ASI-ISP15.2		
PARISIANA ÇEKME KOL PULL HANDLE - PARISIANA	KOLİ MİKTARI/Package Adet / Piece		İSPANYOLET KİLİTLEME (1000mm) MULTI POINT LOCK	KOLİ MİKTARI/Package Adet / Piece	
ASI-SH 002			ASI-ISP15.3		
KIBRIS HAVUZ KOL EMBEDDED HANDLE - CYPRUS	KOLİ MİKTARI/Package Adet / Piece		İSPANYOLET KİLİTLEME (1800mm) MULTI POINT LOCK	KOLİ MİKTARI/Package Adet / Piece	
ASI-SH 004			ASI-ISP K01		
KLICKLOCK HAVUZ KOL EMBEDDED HANDLE CLICKLOCK	KOLİ MİKTARI/Package Adet / Piece		İSPANYOLET KİLİT KARŞILIK MULTI POINT LOCK STRIKER	KOLİ MİKTARI/Package Adet / Piece	
ASI-SH 007			ASI-WH 002		
HAVUZ KOL EMBEDDED HANDLE	KOLİ MİKTARI/Package Adet / Piece		İSPANYOLET KİLİTLEME KOL MULTI POINT LOCK HANDLE	KOLİ MİKTARI/Package Adet / Piece	
ASI-SH 007A			SL40-DB 3570		
KİLİTLİ HAVUZ KOL EMBEDDED HANDLE WITH LOCK	KOLİ MİKTARI/Package Adet / Piece		KANAT SABİTLEME PARÇASI SASH FIXING	KOLİ MİKTARI/Package Adet / Piece	

❗ Sipariş öncesi kalıp bilgisi kontrol edilmeli

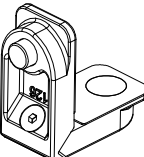
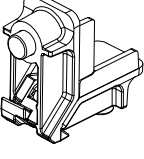
AKSESUAR LİSTESİ - ACCESSORIES LIST

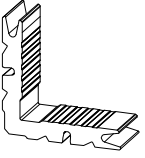
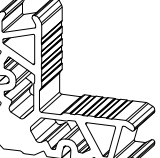
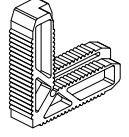

ASI-INR 01				
ÇELİK RAY STEEL RAIL	KOLİ MİKTARI/Package 3 mt / Adet			
ASI-SB 19				
KÖŞE GÖNYESİ CORNER ALIGNMENT	KOLİ MİKTARI/Package 1000 Adet / Piece			
ASI-P 100.1				
ORTA KAYIT BAĞLANTI T JOINT FIXING	KOLİ MİKTARI/Package 250 Adet / Piece			
ASI-PB 1126				
PİMLİ KÖŞE BAĞLANTI CORNER JOINT	KOLİ MİKTARI/Package Adet / Piece			
ASI-PB 2326				
PİMLİ KÖŞE BAĞLANTI CORNER JOINT	KOLİ MİKTARI/Package Adet / Piece			
ASI-PB 219				
KÖŞE BAĞLANTI CORNER JOINT	KOLİ MİKTARI/Package Adet / Piece			
ASI-KT 1126				
KÖŞE TAKOZU CORNER JOINT	KOLİ MİKTARI/Package Adet / Piece			
ASI-KT 2326				
KÖŞE TAKOZU CORNER JOINT	KOLİ MİKTARI/Package Adet / Piece			
ASI-BZ 5007				
SİNEKLİK KÖŞE TAKOZU FLYSCREEN CORNER JOINT	KOLİ MİKTARI/Package Adet / Piece			

PROFİL DETAYLARI
PROFILE DETAILS

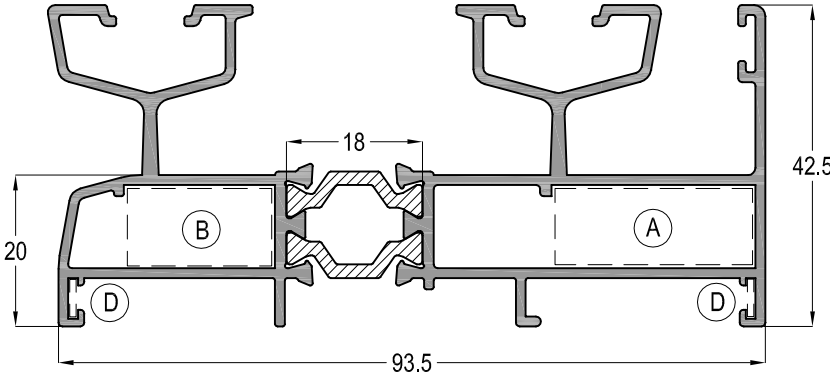
ASİSTANT
ASİSTANT
ASİSTANT



SL40T 01



 (A) ASH-KT 1126 ~ ASI-PB 1126	 (B) ASH-KT 1119 ~ ASI-PB 1119	 (D) ASI-SB 19	AĞIRLIK / Weight
			1,676 kg/mt

SL40T 02

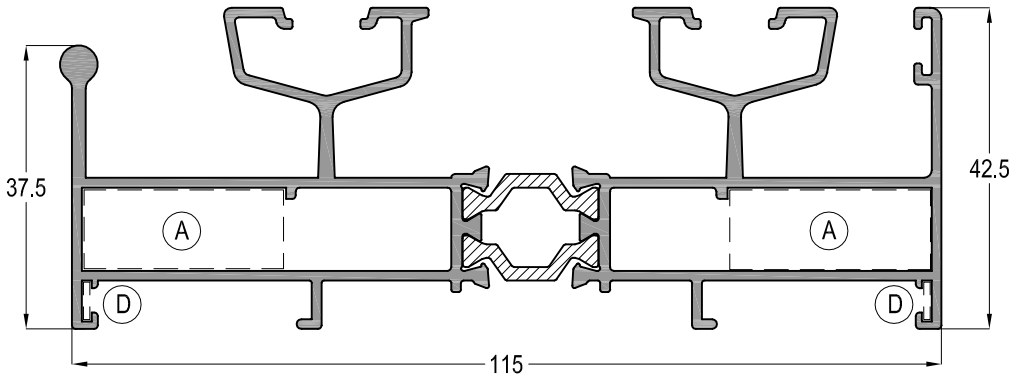

 (A) ASH-KT 1126 ~ ASI-PB 1126	 (D) ASI-SB 19	AĞIRLIK / Weight
		1,968 kg/mt



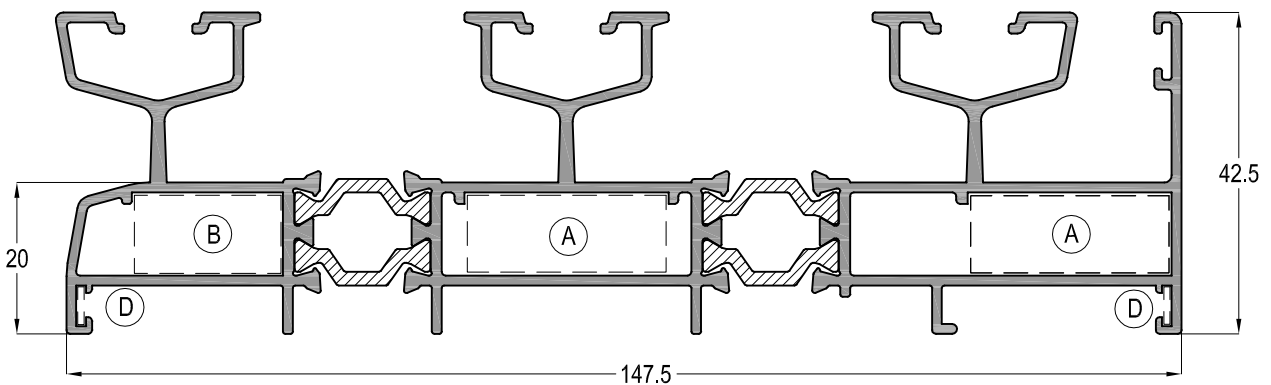

SL40T 03

 (A) ASH-KT 1126 ~ ASI-PB 1126	 (B) ASH-KT 1119 ~ ASI-PB 1119	 (D) ASI-SB 19	AĞIRLIK / Weight
			2,569 kg/mt



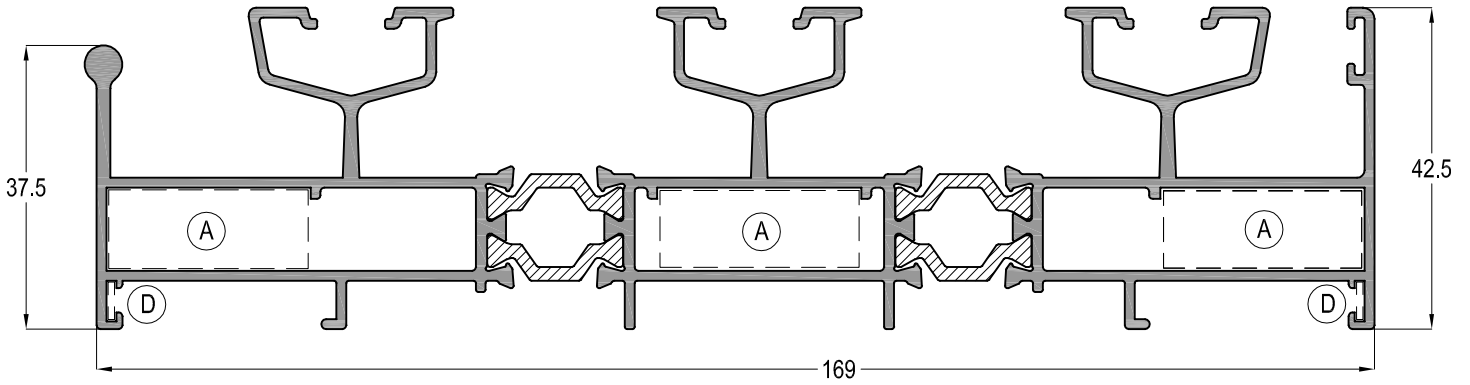

SL40T 05		
 (A)	 (D)	AĞIRLIK / Weight
ASI-KT 1126 ~ ASI-PB 1126	ASI-SB 19	2,862 kg/mt

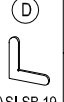

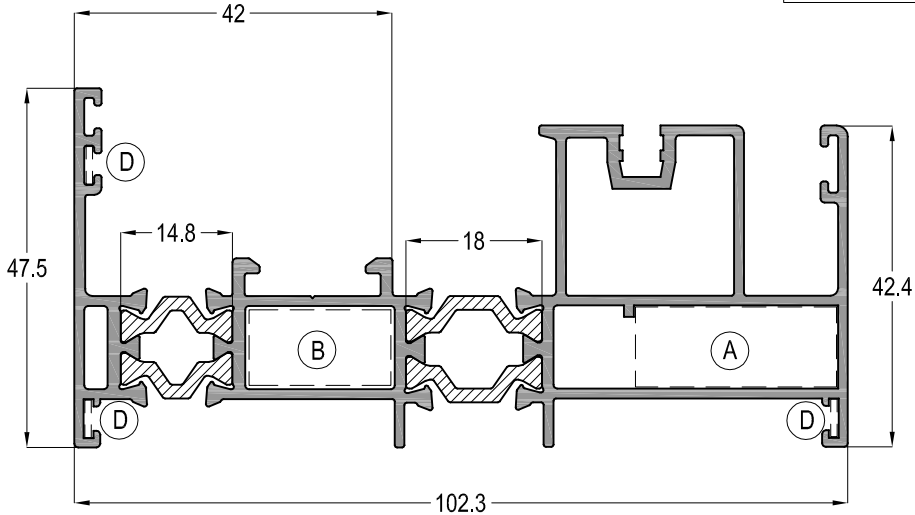

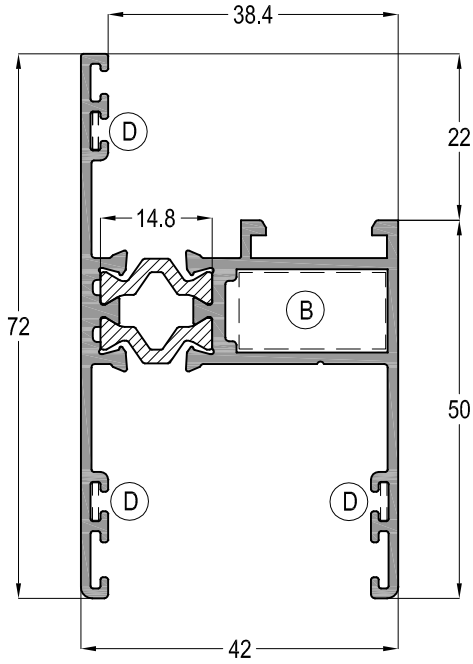
SL40T 04			
 (A)	 (B)	 (D)	AĞIRLIK / Weight
ASI-KT 1126 ~ ASI-PB 1126	ASI-KT 1119 ~ ASI-PB 1119	ASI-SB 19	1,933 kg/mt



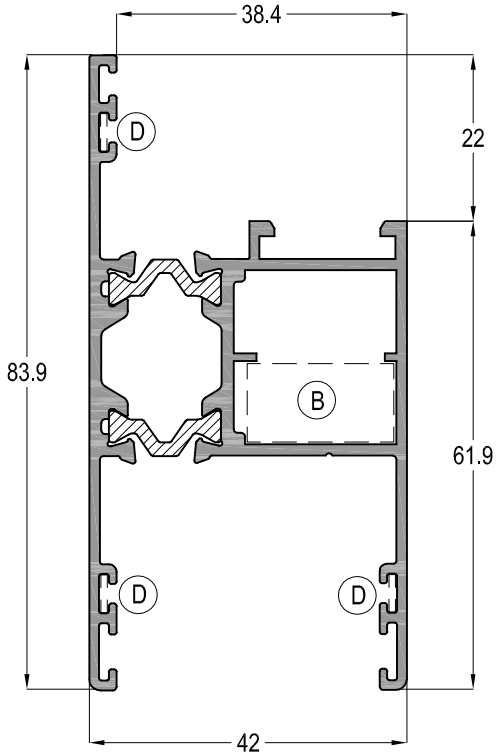

SL40T 11	Jx cm ⁴	Jy cm ⁴
	10,64	10,35
 ASI-KT 1119 ~ ASI-PB 1119 ASI-SB 19	AĞIRLIK / Weight	
	1,092 kg/mt	



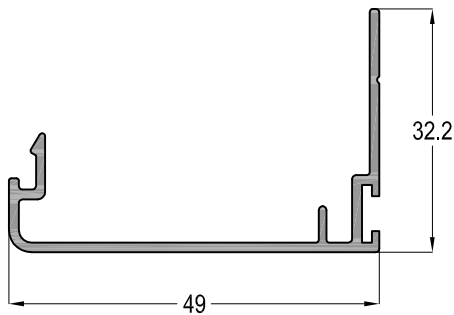

SL40T 12	Jx cm ⁴	Jy cm ⁴
	12,43	18,20
 ASI-KT 1119 ~ ASI-PB 1119 ASI-SB 19	AĞIRLIK / Weight	
	1,318 kg/mt	

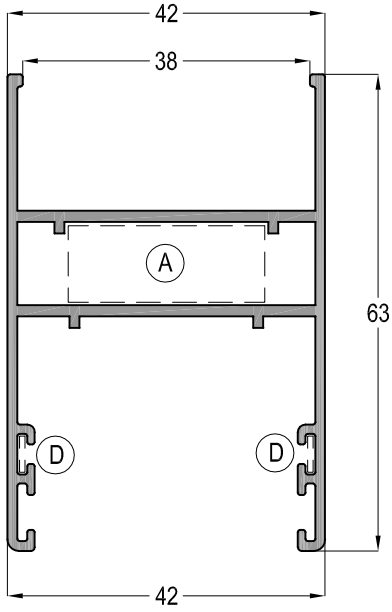

SL40T 41	AĞIRLIK / Weight
	0,372 kg/mt



SL40 13	Jx cm ⁴	Jy cm ⁴
	9,43	8,09
 	AĞIRLIK / Weight	
	0,865 kg/mt	

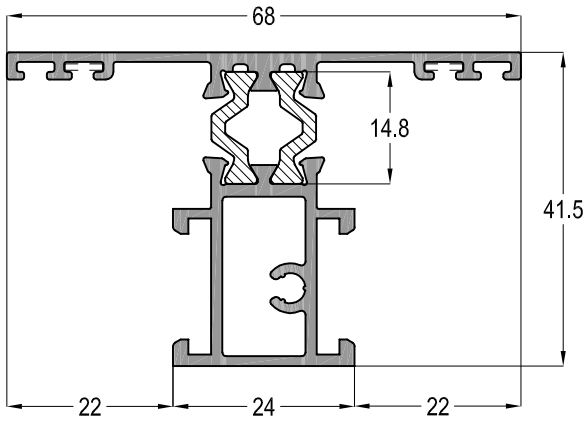

SL40T 21	
	AĞIRLIK / Weight
	1,004 kg/mt

LS60 71	
	AĞIRLIK / Weight
	2,050 kg/mt

LS60 72	
	AĞIRLIK / Weight
	0,420 kg/mt

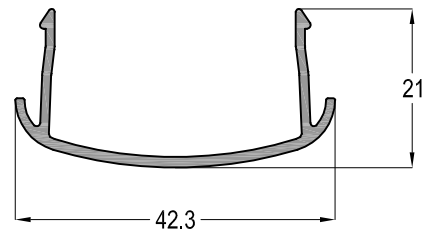
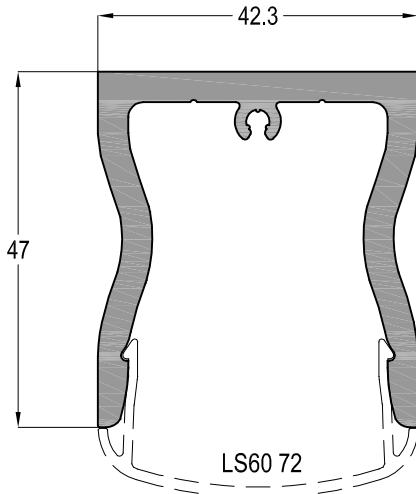

SL40T 42	
 SL40-KP02	AĞIRLIK / Weight
	0,738 kg/mt

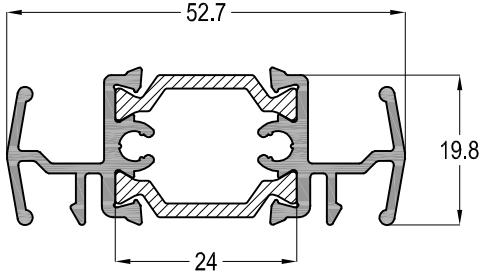

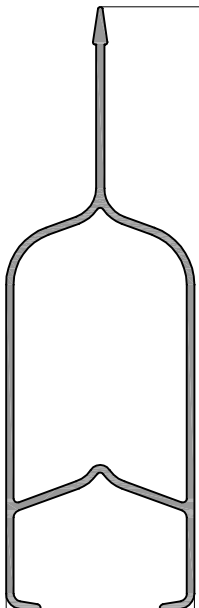
SL40 72	
	AĞIRLIK / Weight
	0,986 kg/mt

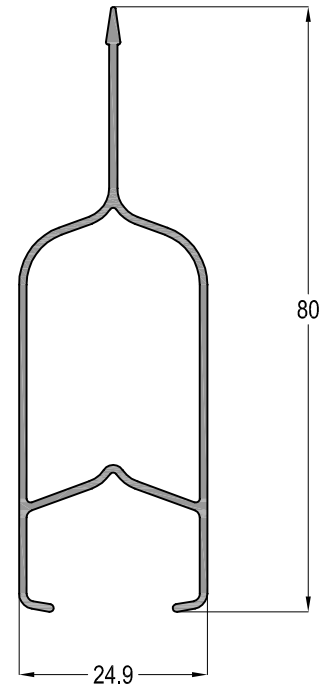

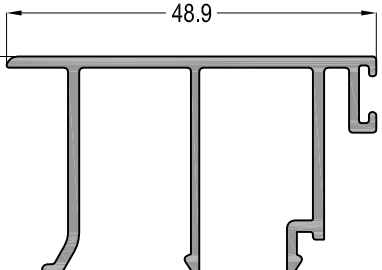
SL40 81	
	AĞIRLIK / Weight
	0,572 kg/mt

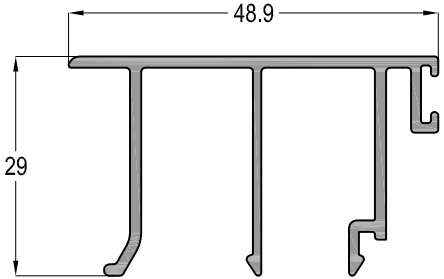

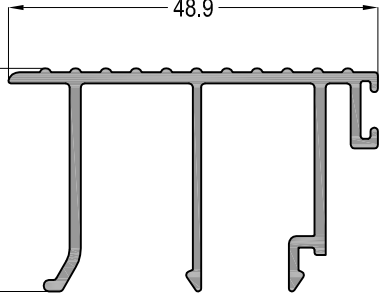
SL40 82	
	AĞIRLIK / Weight
	0,588 kg/mt

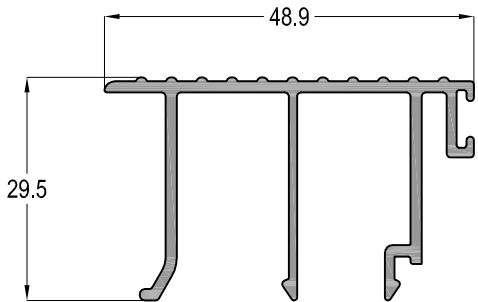

SL40 73	
	AĞIRLIK / Weight
	0,245 kg/mt

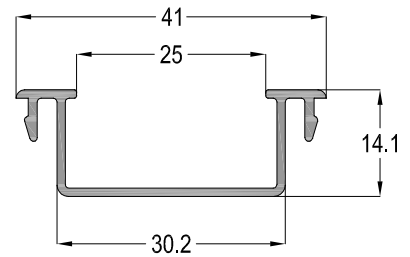

15-304216-09		
		AĞIRLIK / Weight
ASI-BZ 5007	ASI-BZ 5060	0,352 kg/mt

15-306317-11		
		AĞIRLIK / Weight
ASI-BZ 5007	ASI-BZ 5060	0,561 kg/mt

SL40 64	
	AĞIRLIK / Weight
	0,478 kg/mt

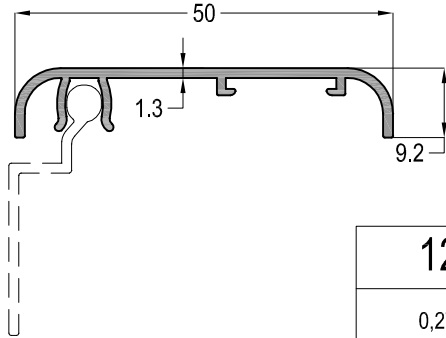
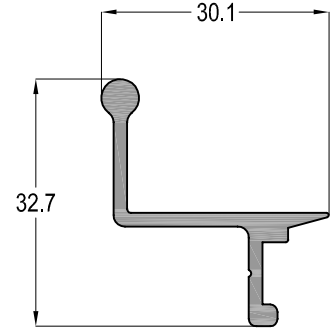
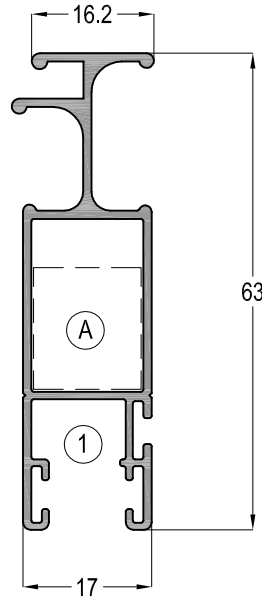
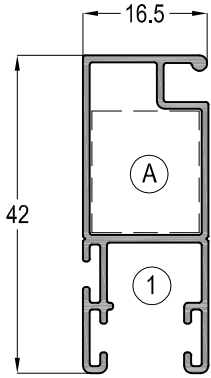

12-52
0,279 kg/mt

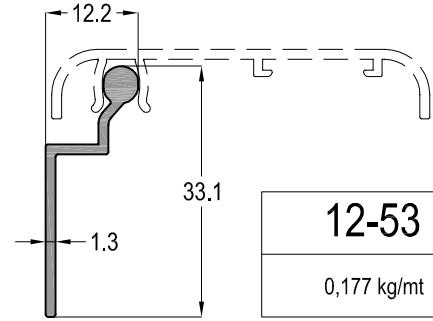

12-53
0,177 kg/mt

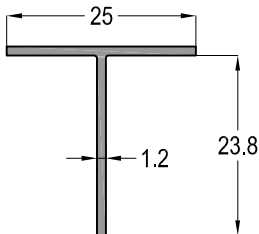

04-025025-12
0,158 kg/mt

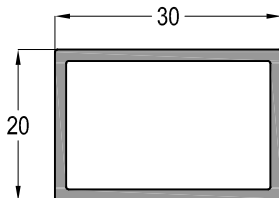

02-030020-15
0,382 kg/mt

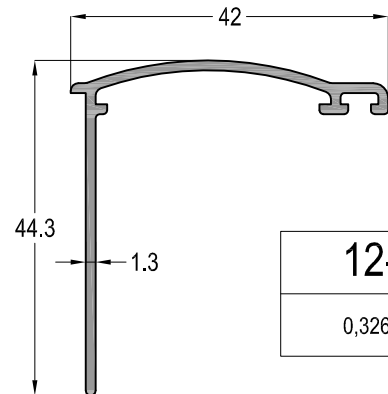

12-54
0,326 kg/mt

SL40 61	
	AĞIRLIK / Weight
	0,148 kg/mt

SL40 62	
	AĞIRLIK / Weight
	0,134 kg/mt

SL40 63	
	AĞIRLIK / Weight
	0,132 kg/mt

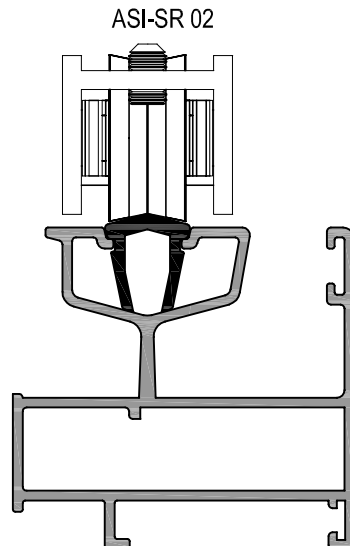
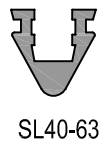
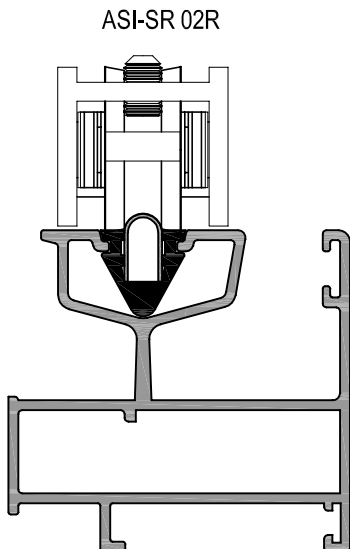
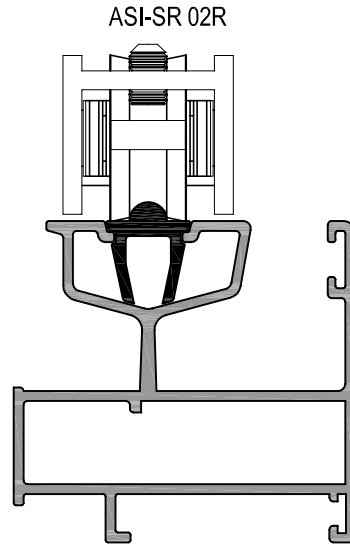
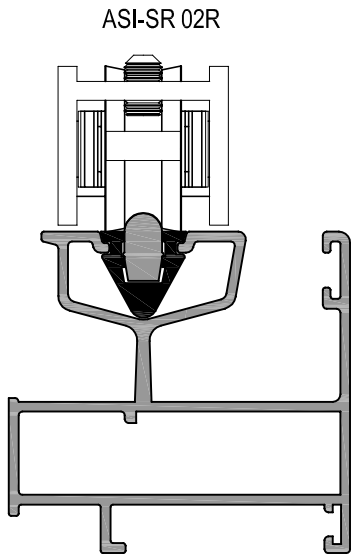
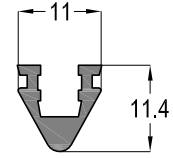
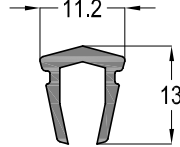
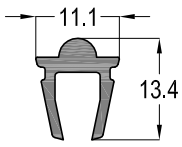

SL40T 11 ve SL40T 12 KANATLARI İÇİN SASH FOR SL40T 11 & SL40T 12

CAM KALINLIĞINA GÖRE CAM ÇİTASI SEÇİM TABLOSU
Glazing Bead Selection Table according to the Glass Thickness

CAM KALINLIĞI Glass Thickness (mm)	CAM ÇİTASI Glazing Bead	İÇ CAM FİTİLİ Glass Gasket (IN)	DIŞ CAM FİTİLİ Glass Gasket (OUT)
4	11-026	EP2-03	EP1-01
5	11-026	EP2-02	EP1-01
6	11-026	EP2-01	EP1-01
8	11-022	EP2-03	EP1-01
9	11-022	EP2-02	EP1-01
10	11-022	EP2-01	EP1-01
11	11-020	EP2-02	EP1-01
12	11-020	EP2-01	EP1-01
13	11-017	EP2-03	EP1-01
14	11-017	EP2-02	EP1-01
15	11-017	EP2-01	EP1-01
16	11-015	EP2-02	EP1-01
17	11-015	EP2-01	EP1-01
20	11-010	EP2-03	EP1-01
21	11-010	EP2-02	EP1-01
22	11-010	EP2-01	EP1-01
24	11-006	EP2-03	EP1-01
25	11-006	EP2-02	EP1-01
26	11-006	EP2-01	EP1-01
27	11-004	EP2-02	EP1-01
28	11-004	EP2-01	EP1-01

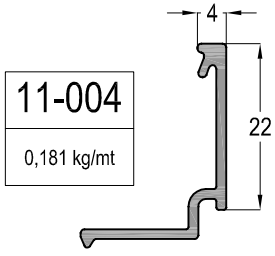

11-006
0,218 kg/mt

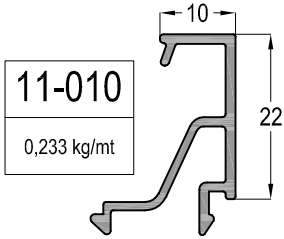
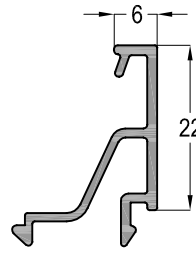

11-015
0,241 kg/mt

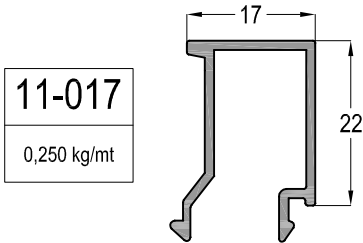
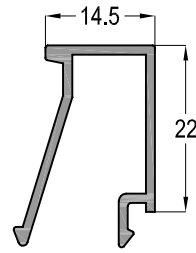

11-020
0,276 kg/mt

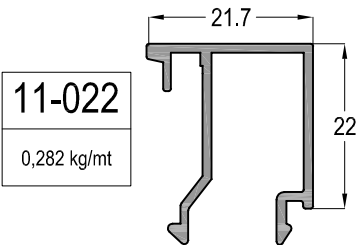
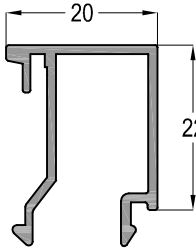

11-026
0,296 kg/mt

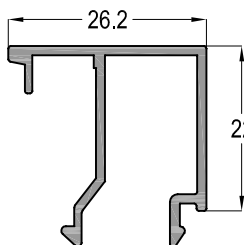

AÇILIM TİPLERİ - OPENING TYPES

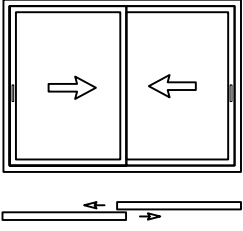

2 HAREKETLİ KANAT
2 SLIDING SASH

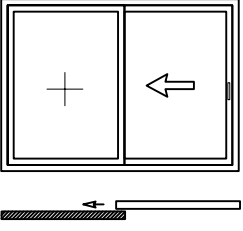

1 HAREKETLİ 1 SABİT KANAT
1 SLIDING 1 FIX SASH

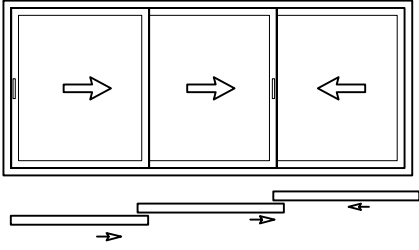

3 HAREKETLİ KANAT
3 SLIDING SASH

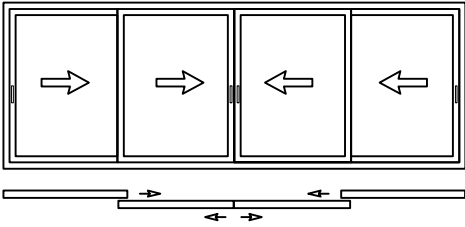

4 HAREKETLİ KANAT
4 SLIDING SASH

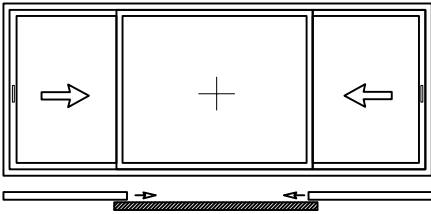

2 HAREKETLİ 1 SABİT KANAT
2 SLIDING 1 FIX SASH

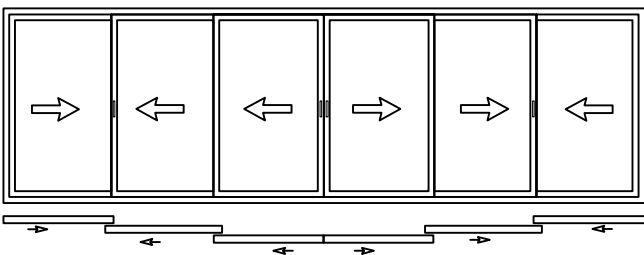

6 HAREKETLİ KANAT
6 SLIDING SASH

RÜZGAR YÜKÜNE GÖRE MAKSİMUM KANAT EBATLARI
MAXIMUM SASH DIMENSIONS FOR GIVEN WIND PRESSURE

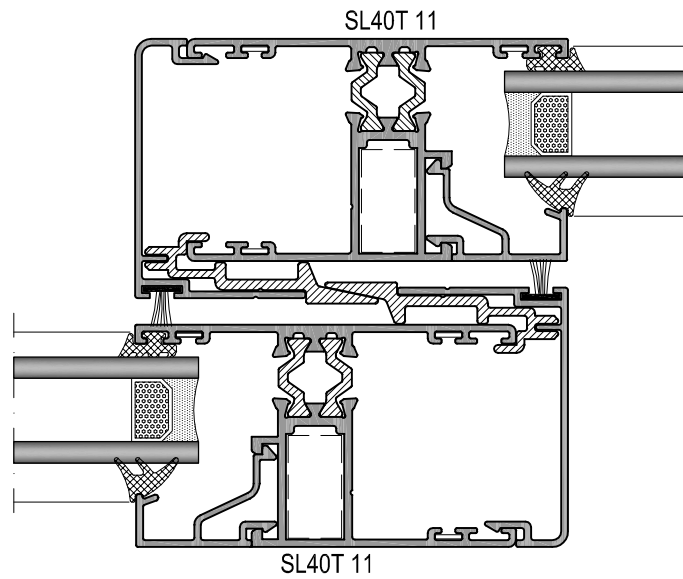
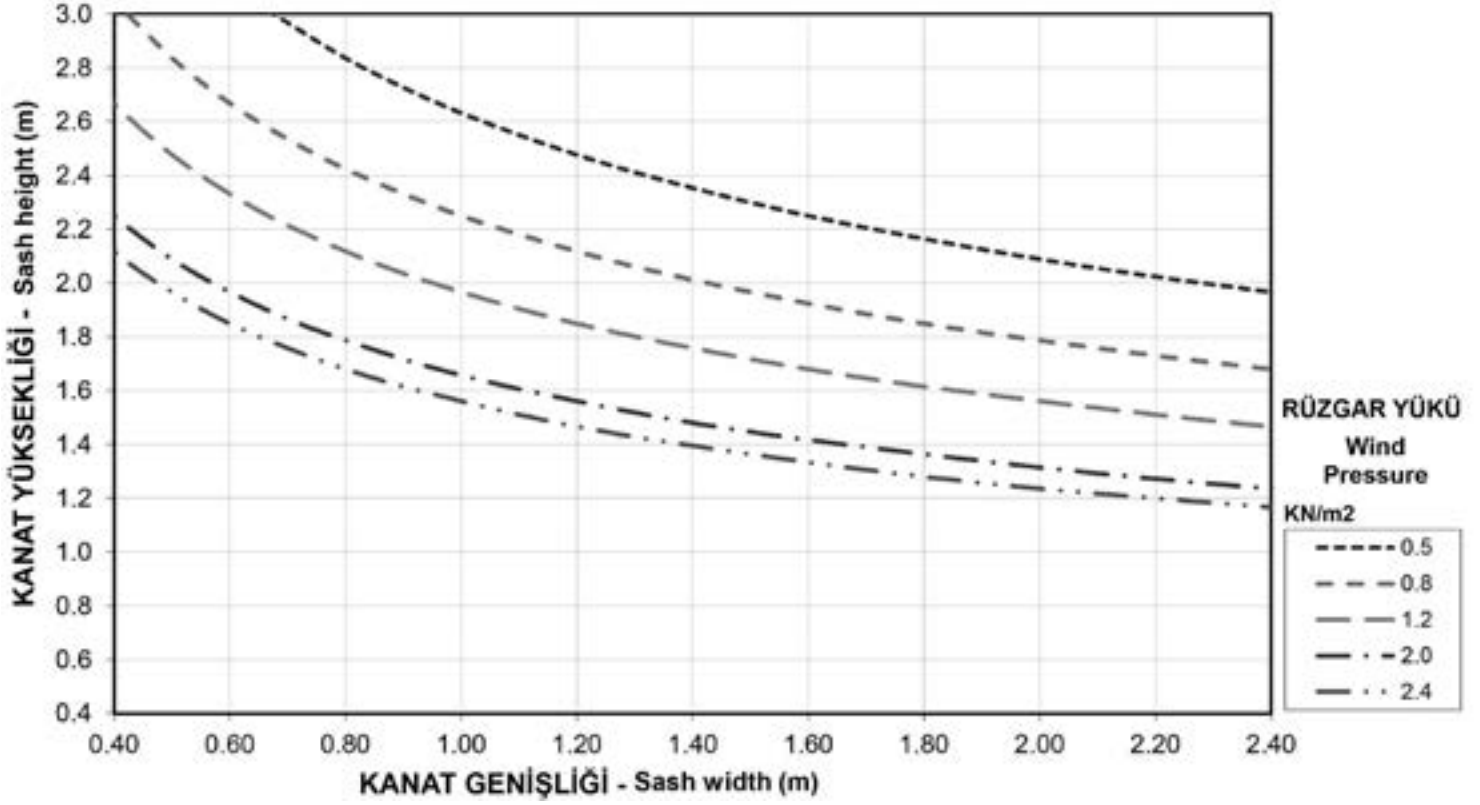

KANAT EBATLARI BELİRLENİRKEN RULMANIN TAŞIMA KAPASİTESİNİ GEÇMEMESİNE DİKKAT EDİLMELİDİR
WHILE THE DETERMINE SASH DIMENSIONS, SASH WEIGHT MUST BE LESS THAN ROLLER CARY CAPACITY

RÜZGAR YÜKÜNE GÖRE MAKSİMUM KANAT EBATLARI
MAXIMUM SASH DIMENSIONS FOR GIVEN WIND PRESSURE

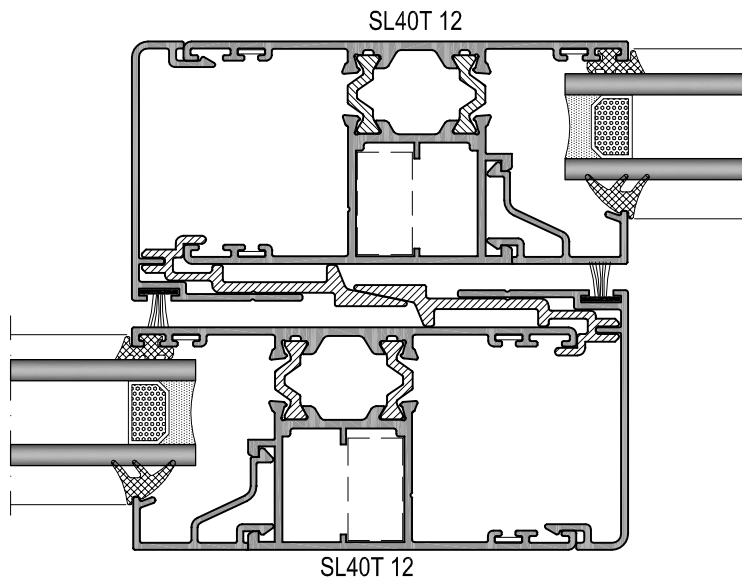
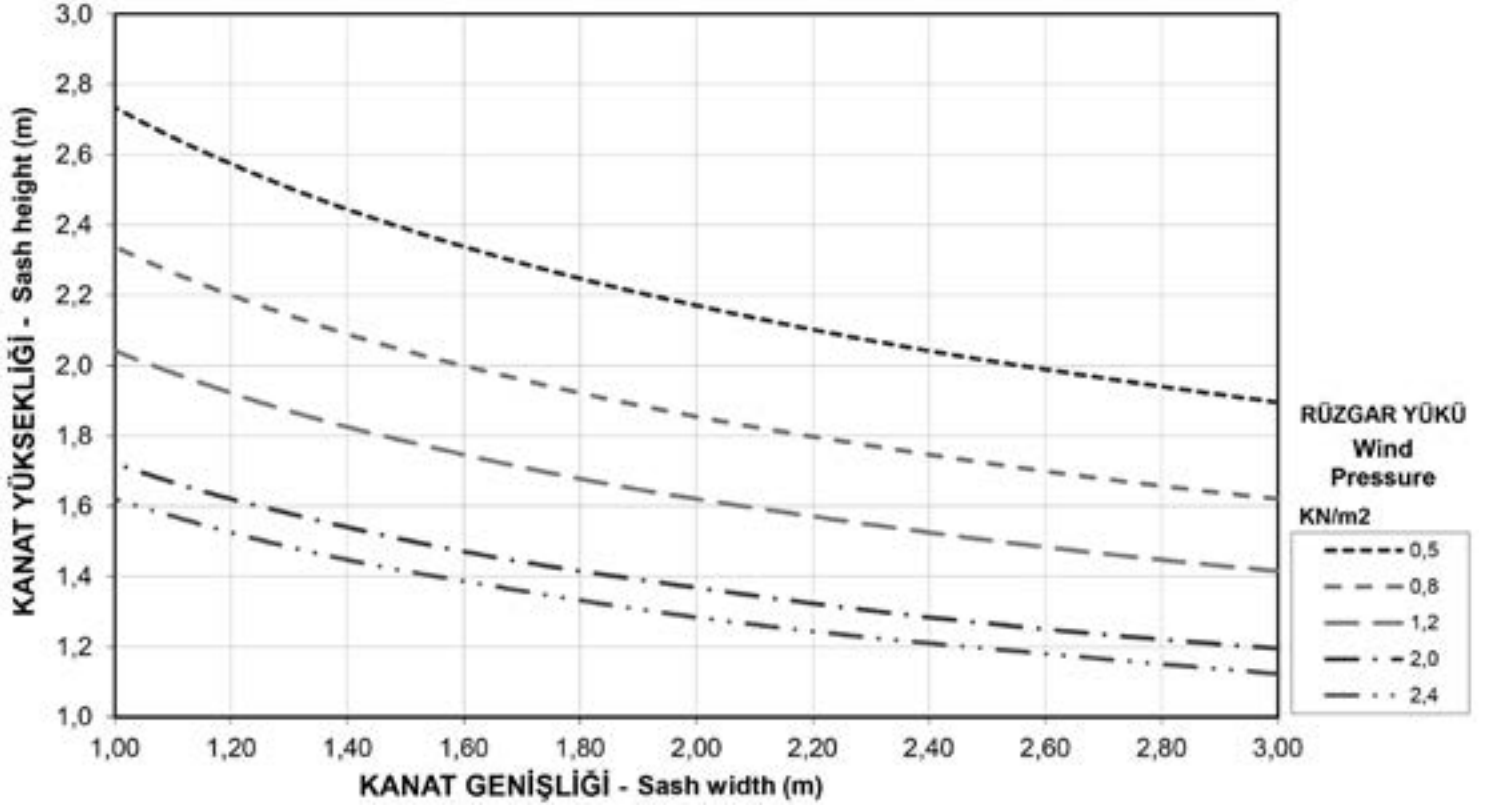

KANAT EBATLARI BELİRLENİRKEN RULMANIN TAŞIMA KAPASİTESİNİ GEÇMEMESİNE DİKKAT EDİLMELİDİR
WHILE THE DETERMINE SASH DIMENSIONS, SASH WEIGHT MUST BE LESS THAN ROLLER CARY CAPACITY

RÜZGAR YÜKÜNE GÖRE MAKSİMUM KANAT EBATLARI
MAXIMUM SASH DIMENSIONS FOR GIVEN WIND PRESSURE

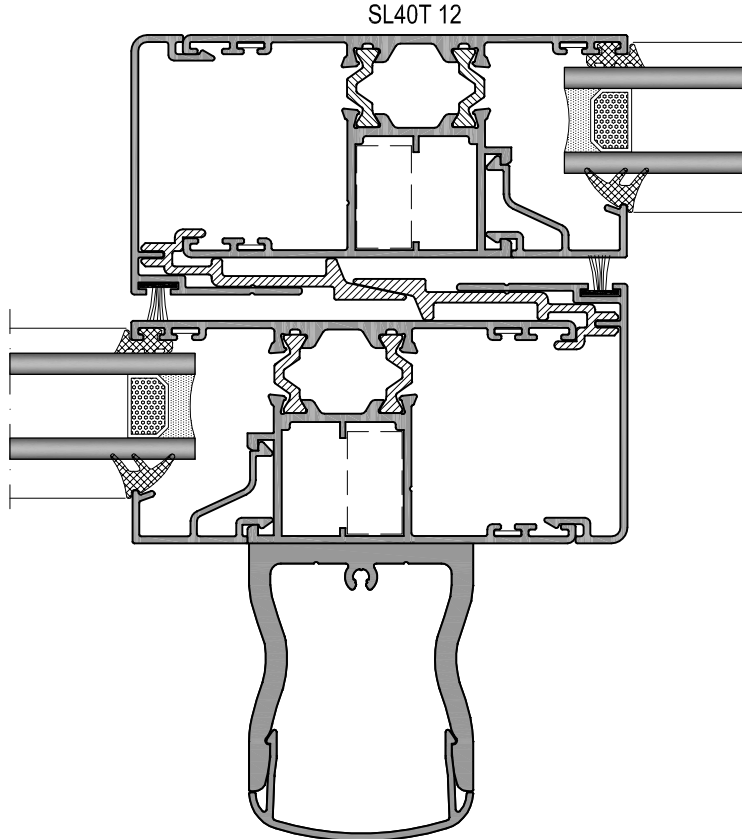
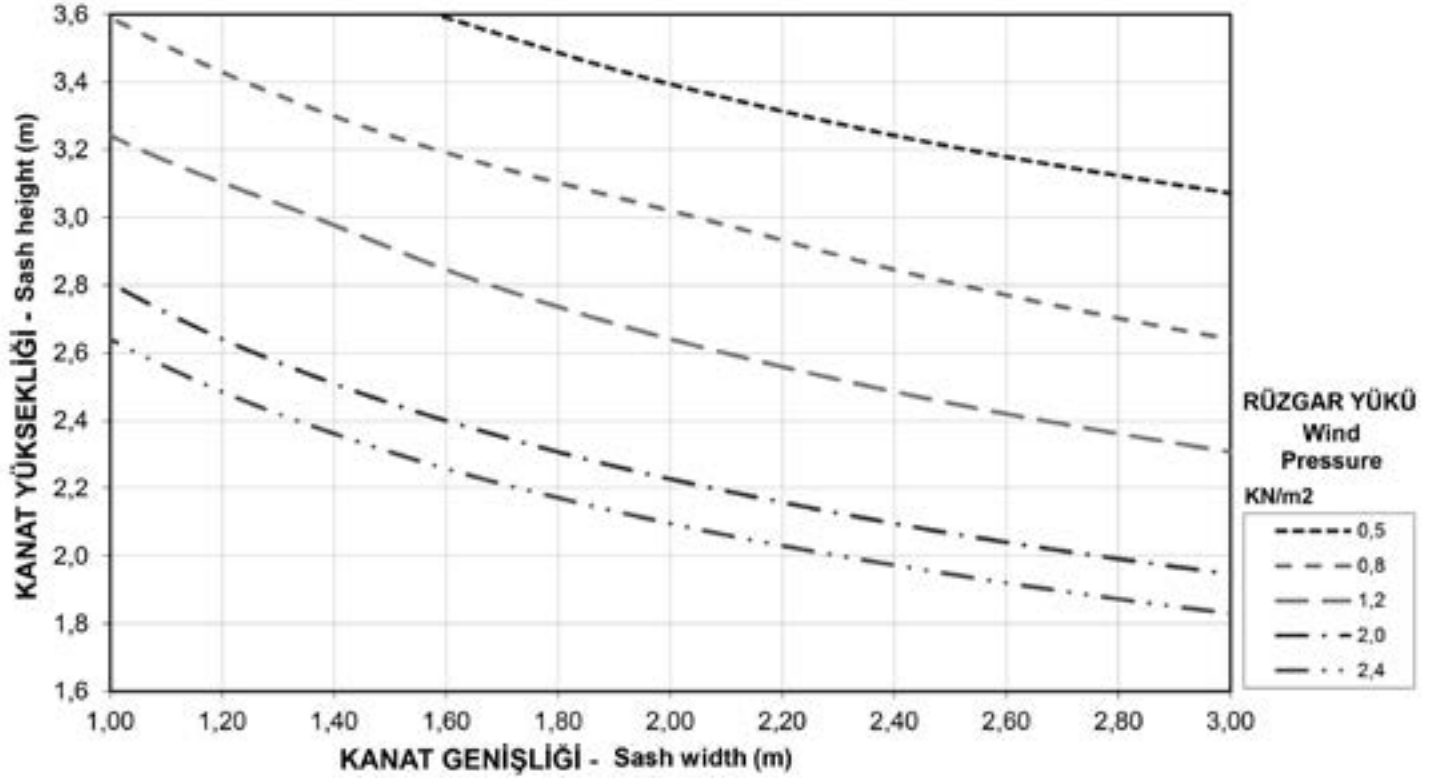

KANAT EBATLARI BELİRLENİRKEN RULMANIN TAŞIMA KAPASİTESİNİ GEÇMEMESİNE DİKKAT EDİLMELİDİR
WHILE THE DETERMINE SASH DIMENSIONS, SASH WEIGHT MUST BE LESS THAN ROLLER CARY CAPACITY

SİSTEM DETAYLARI
SYSTEM DETAILS

ALIASİSİ
ASİSTANT
SİSTEM

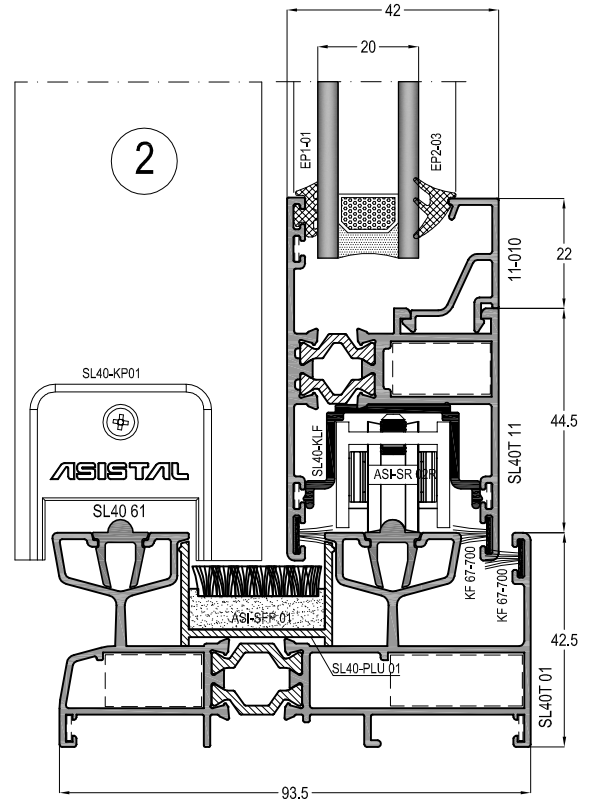
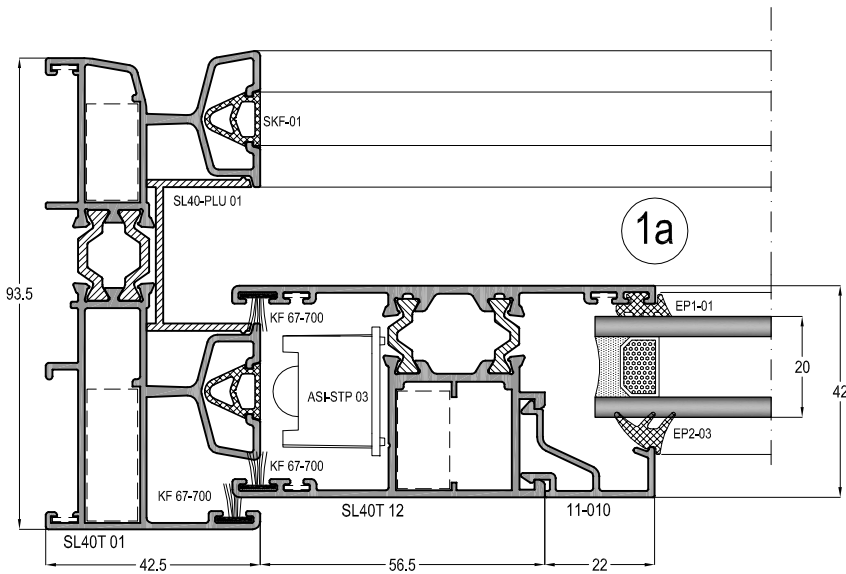
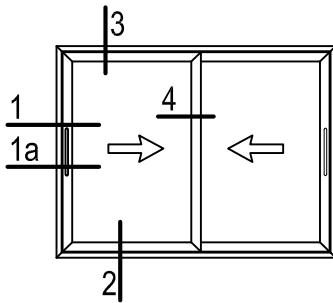
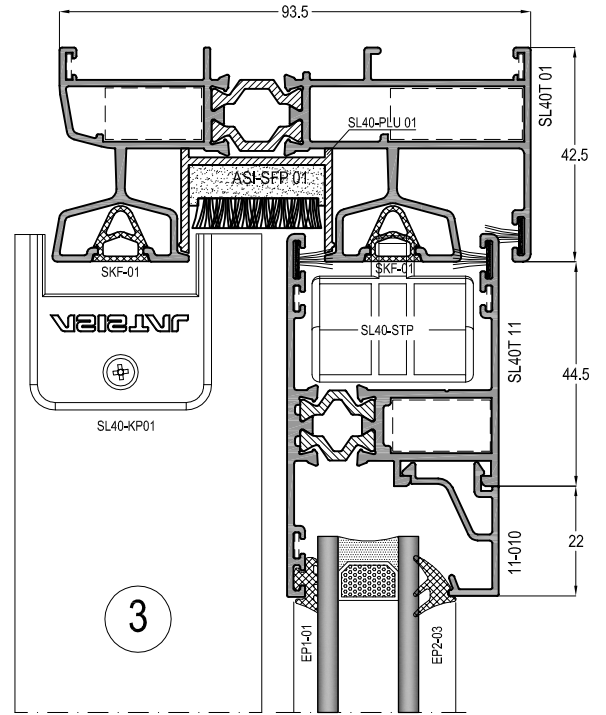
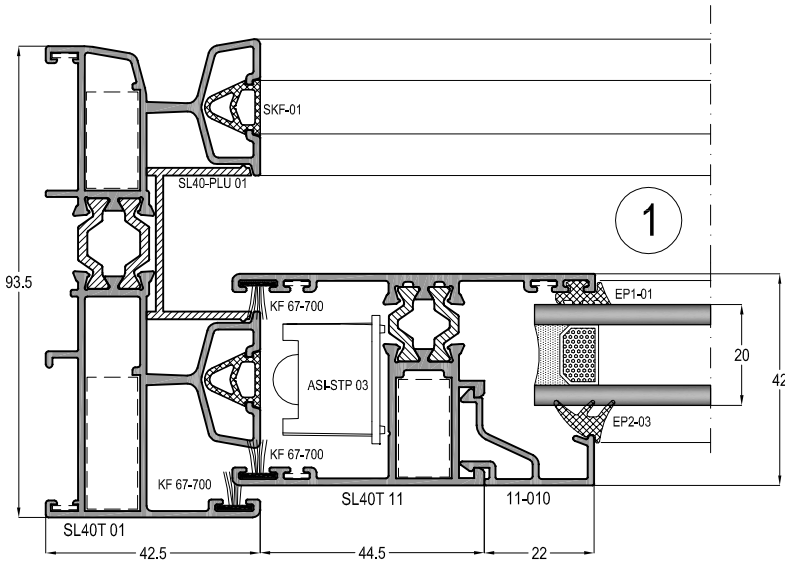

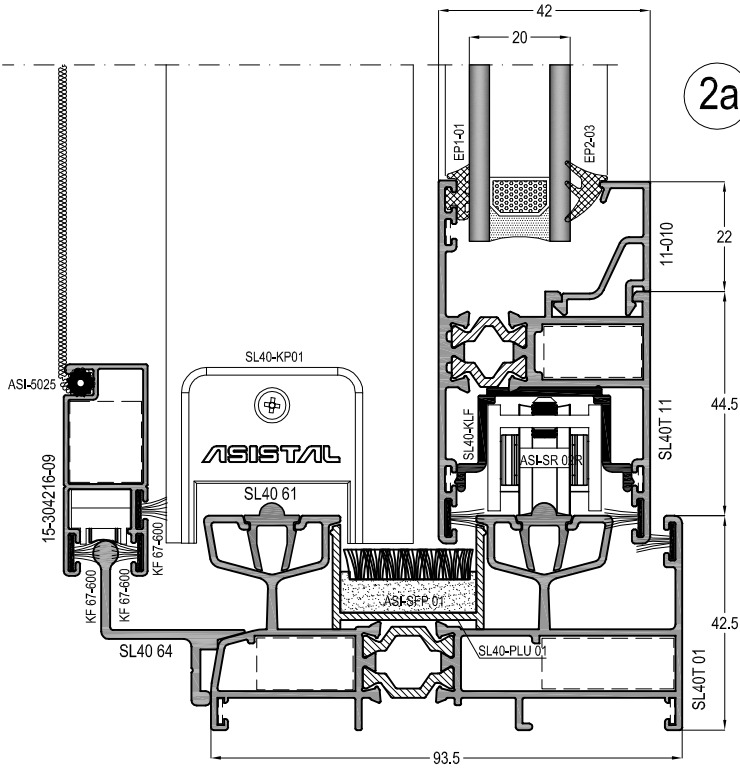

2a

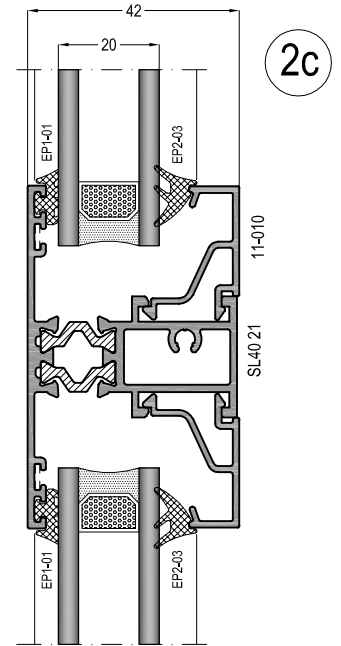

2c

2b

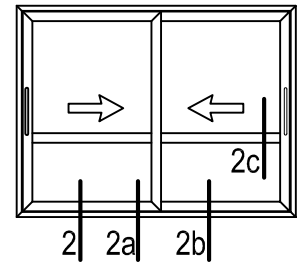
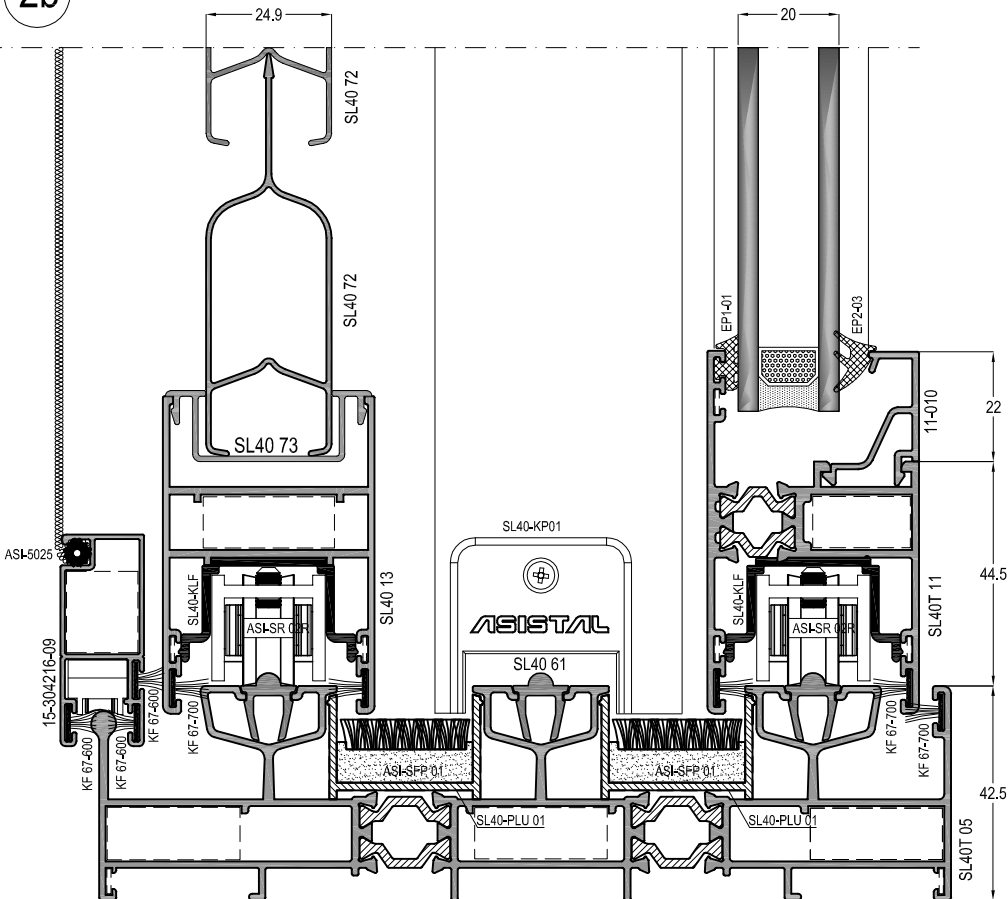

4

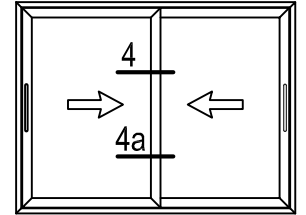
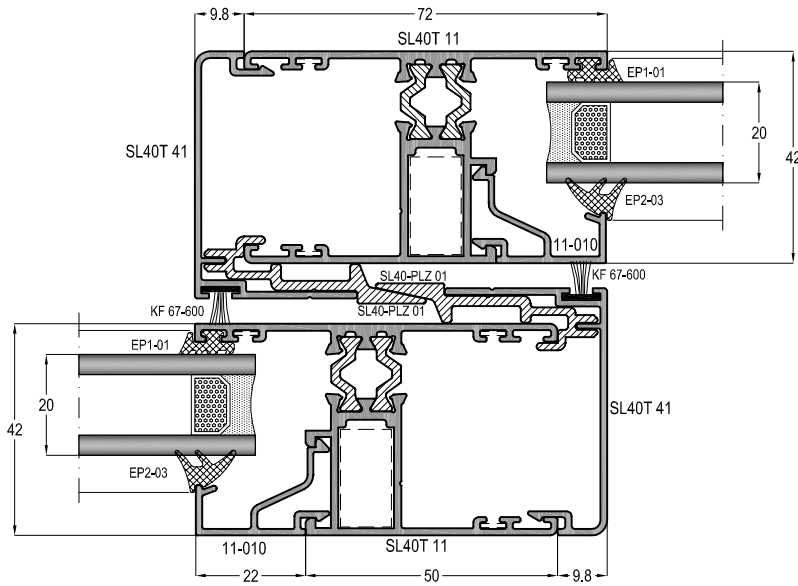

4a

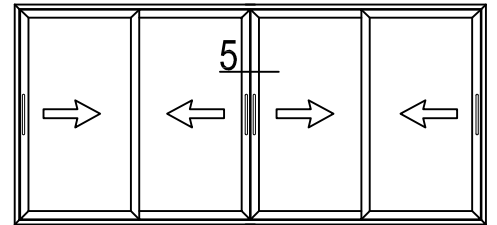
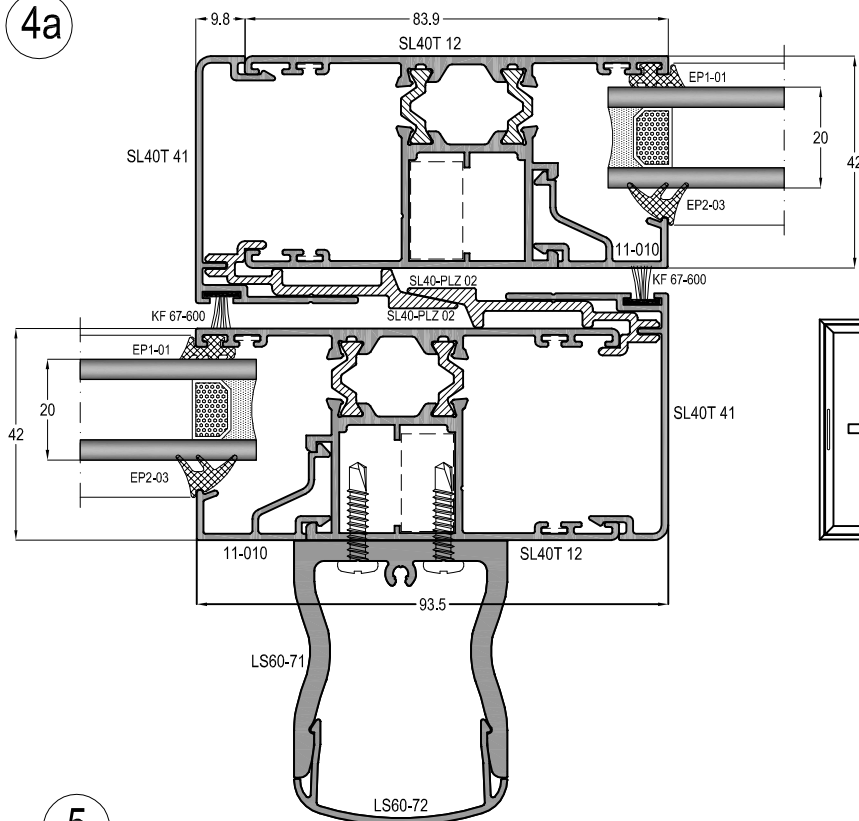

5

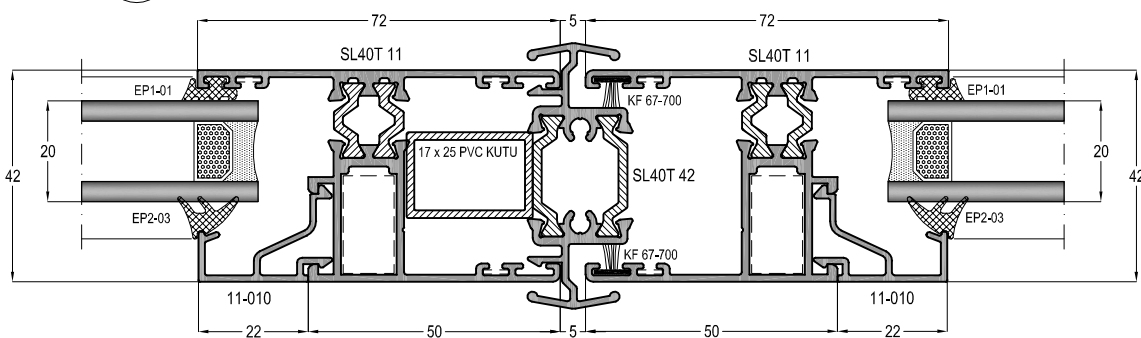

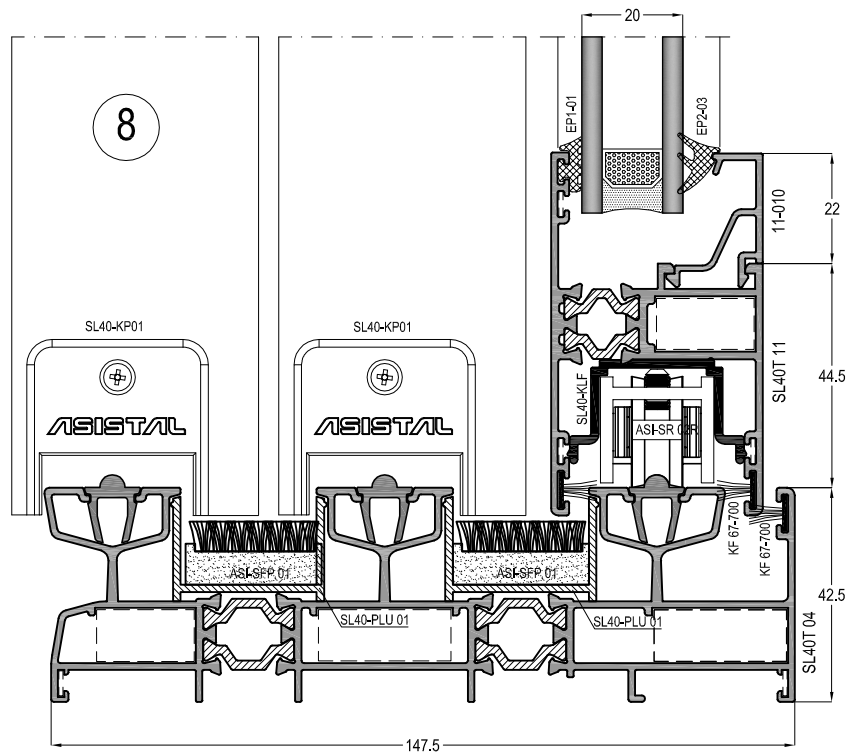
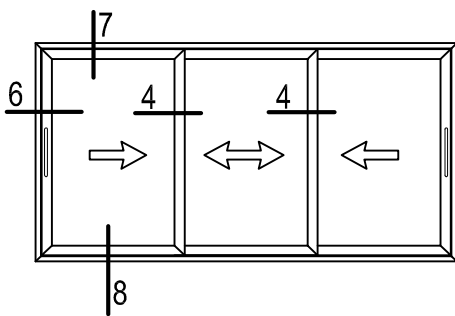
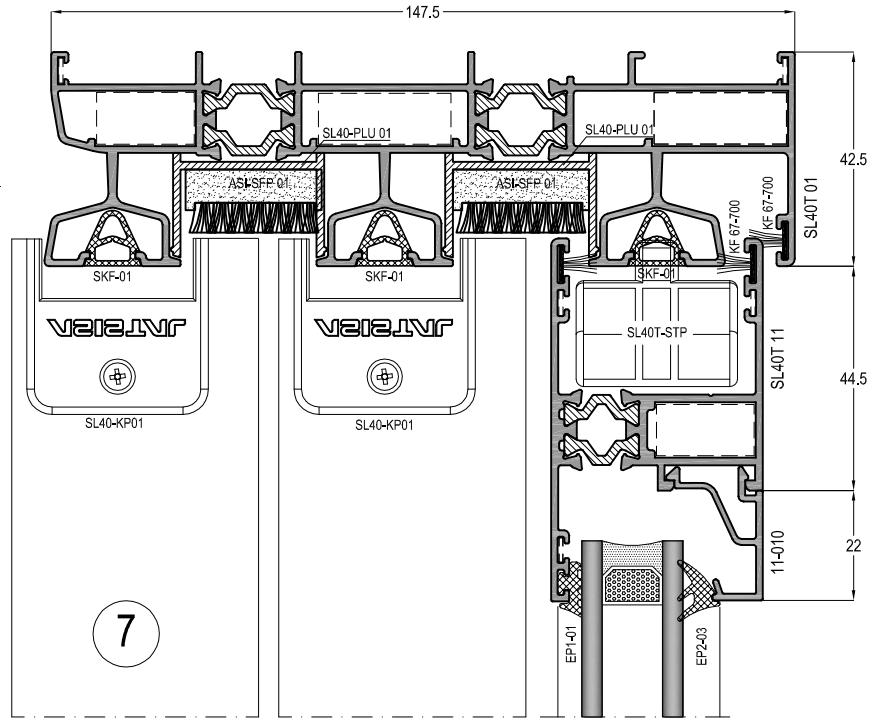
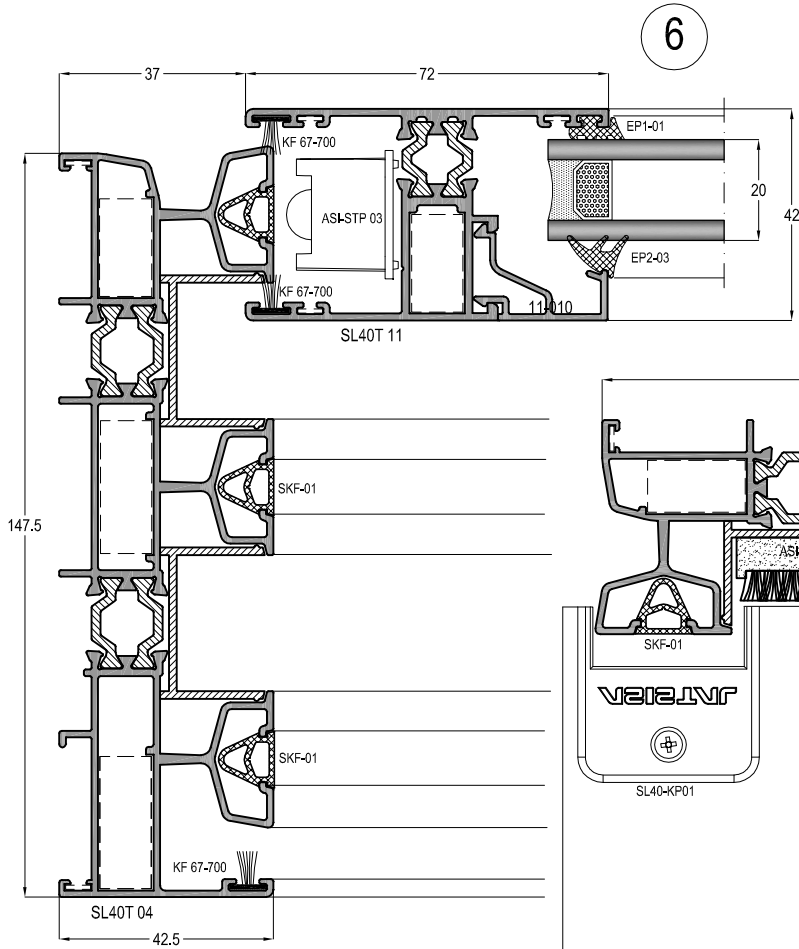

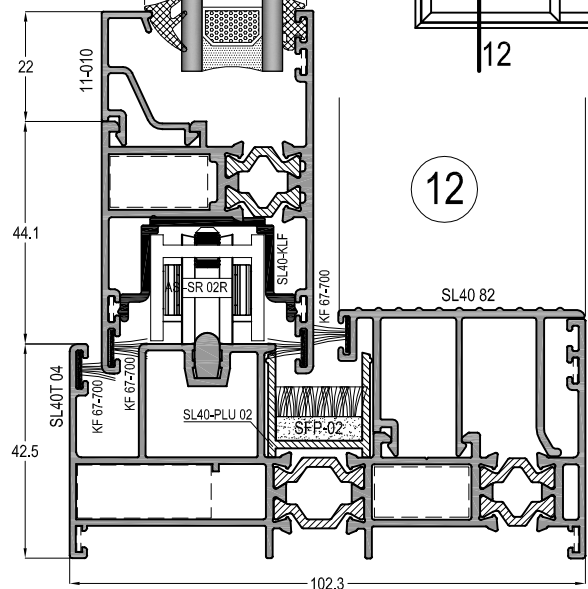
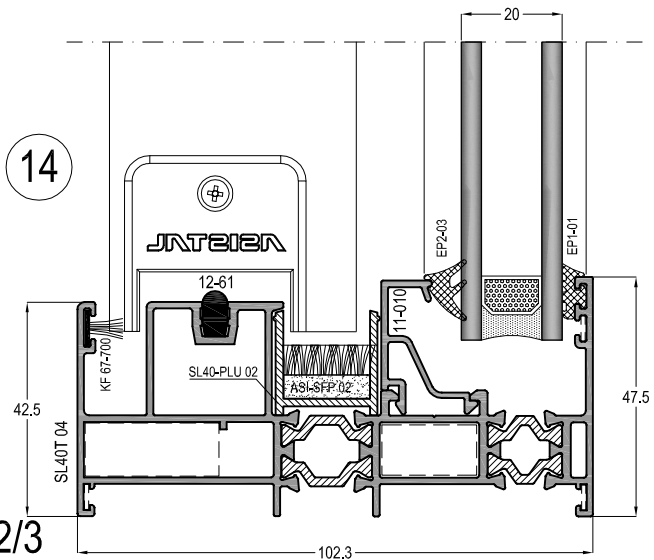
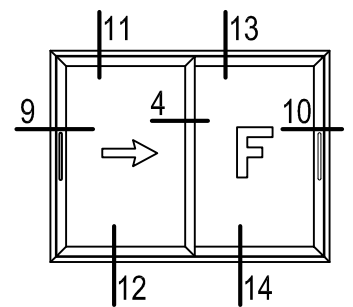
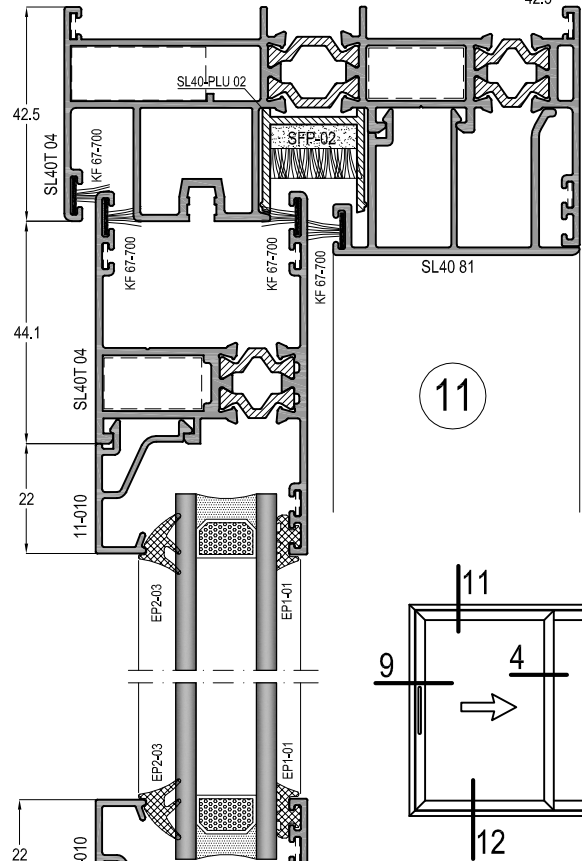
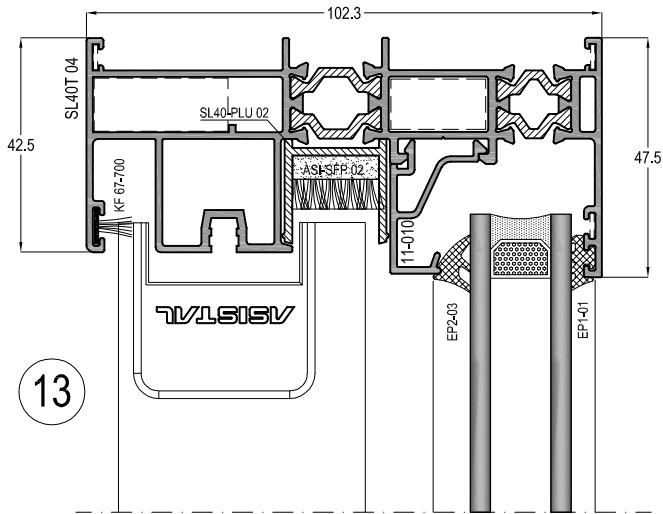
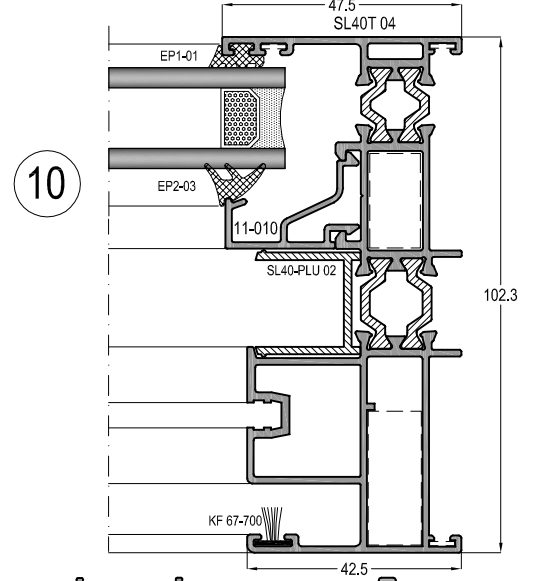
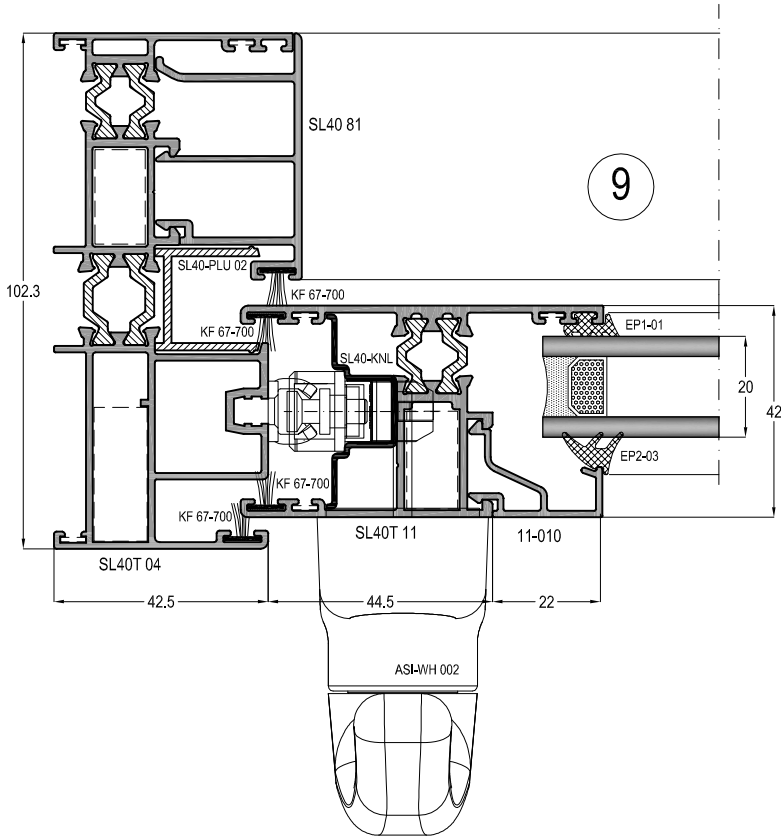

KESİM VE MONTAJ
CUTTING & ASSEMBLY

ALASIS
ASIS
ASIS

PİMLİ KÖŞE BAĞLANTI MONTAJI

ASSEMBLY FOR PIN CONNECTION

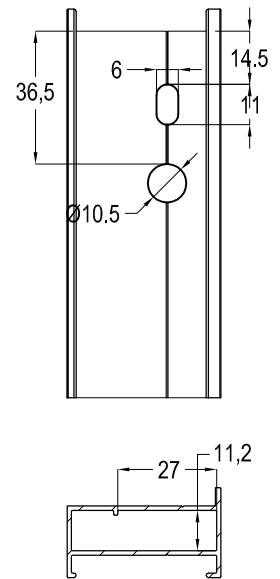
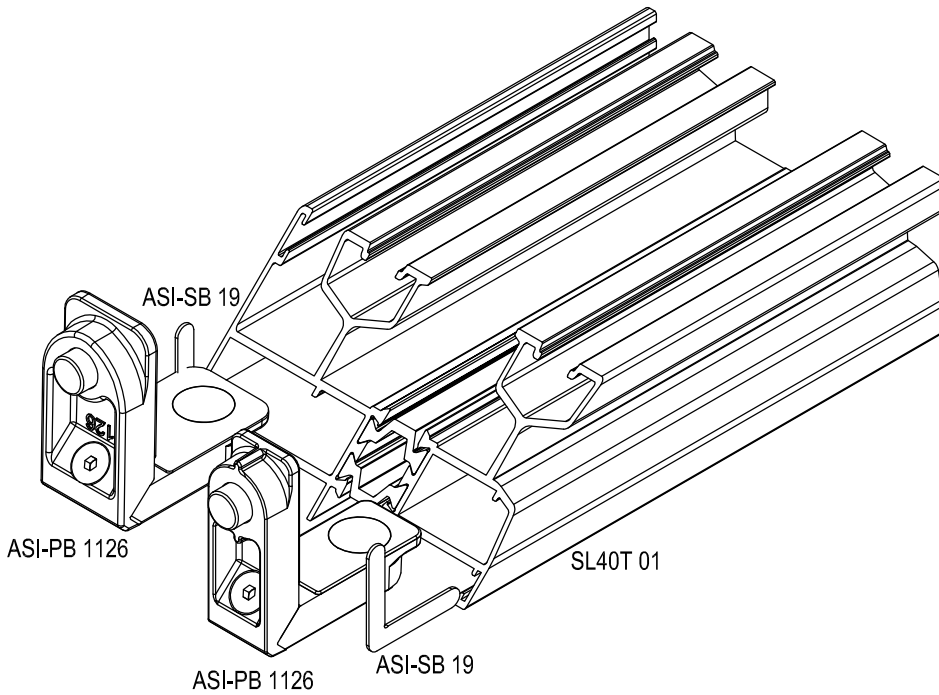
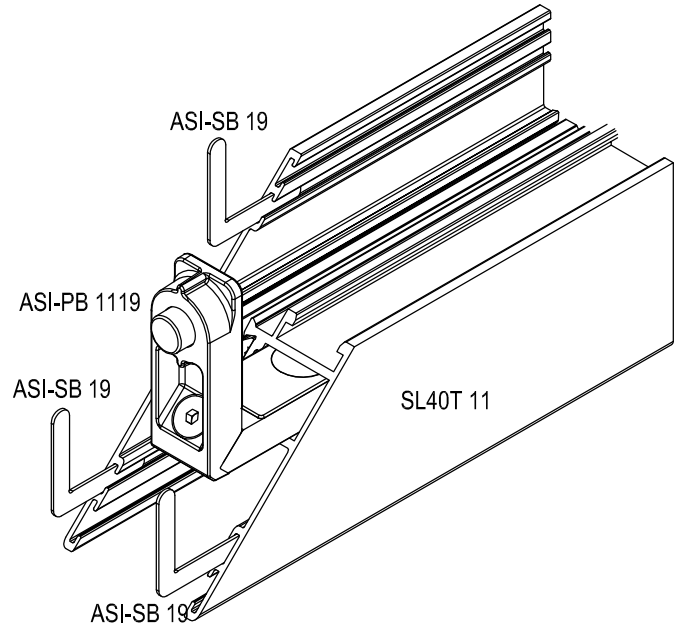
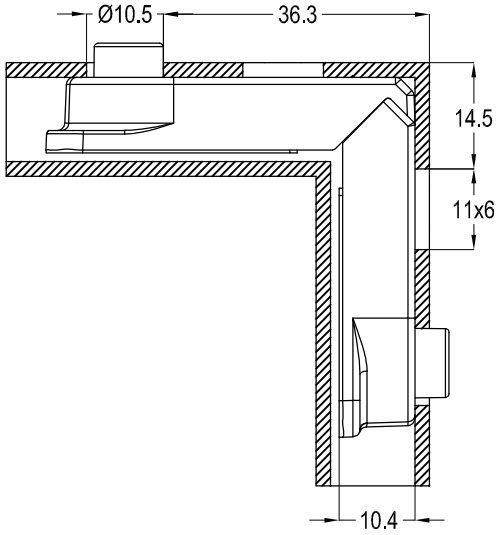

ÇEKME KOL : ASI-SH 001
PULL HANDLE : ASI-SH 001

ASI-SH 001

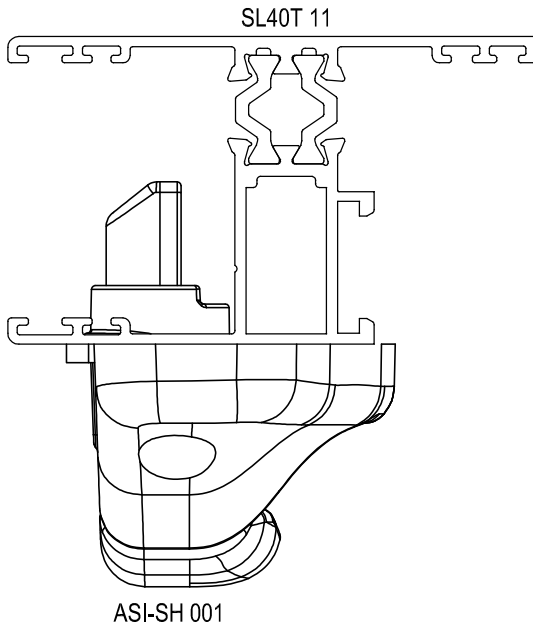
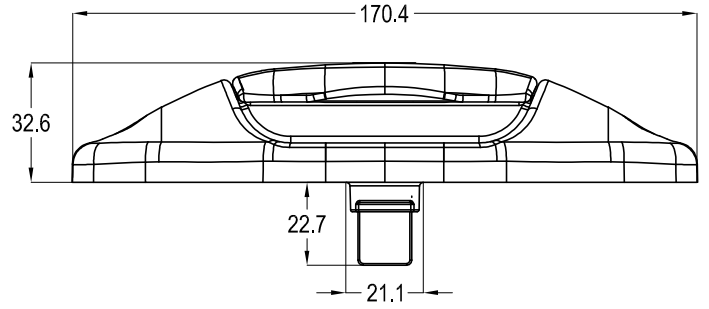

ASI-SH 001

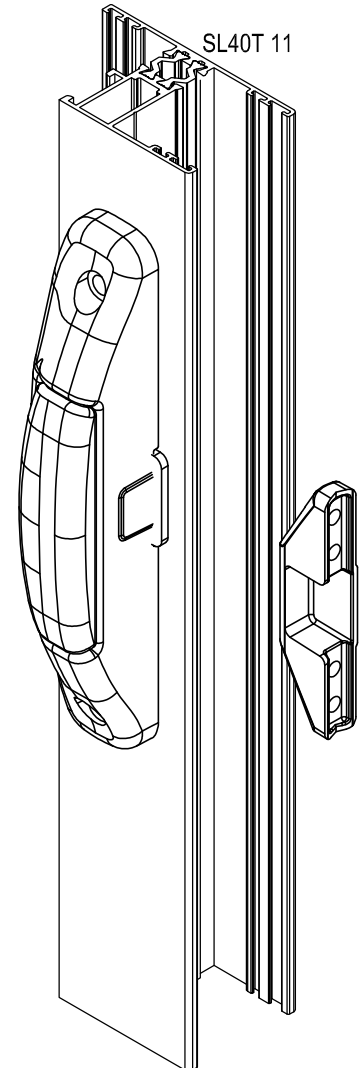

SL40T 11

HAVUZLU KOL : ASI-SH 002
EMBEDED HANDLE : ASI-SH 002

ASI-SH 002



ASI-SH 002

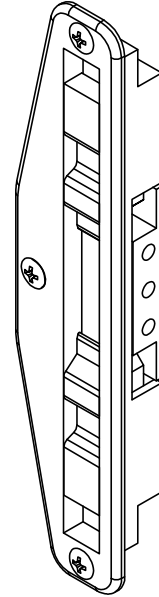

SL40T 11

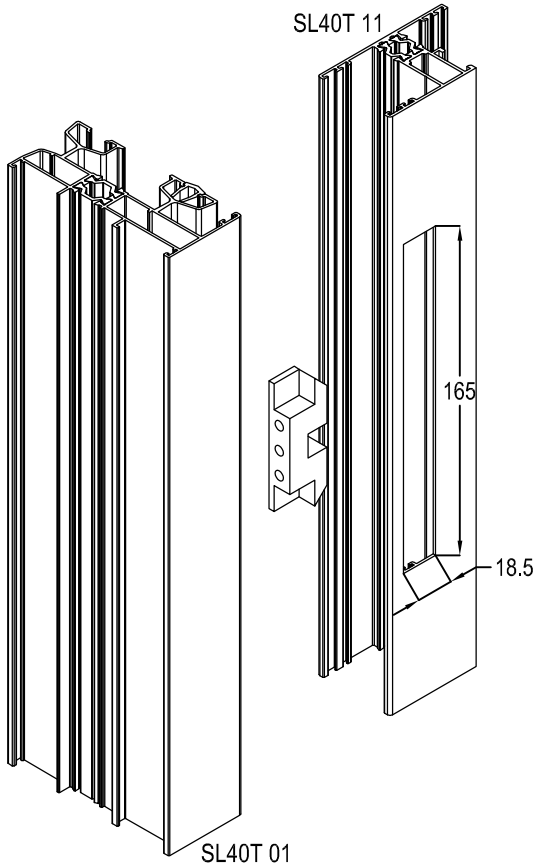

SL40T 01

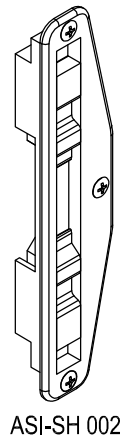

ASI-SH 002

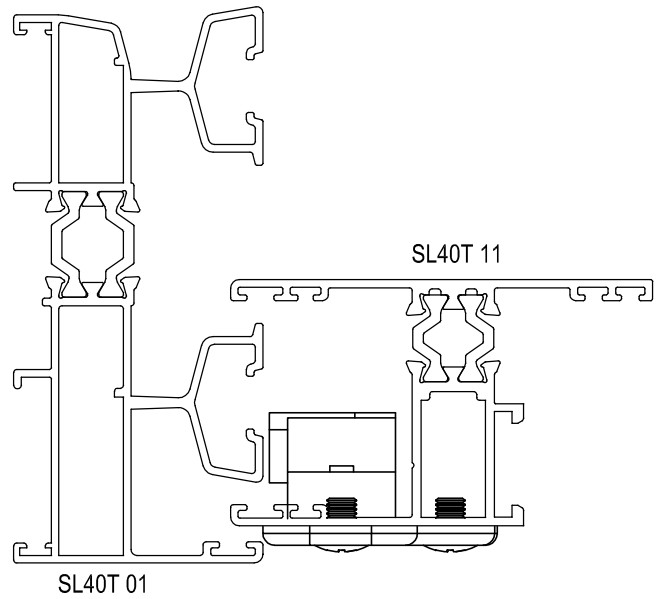

SL40T 01

SL40T 11

HAVUZLU KOL : ASI-SH 004
EMBEDED HANDLE : ASI-SH 004

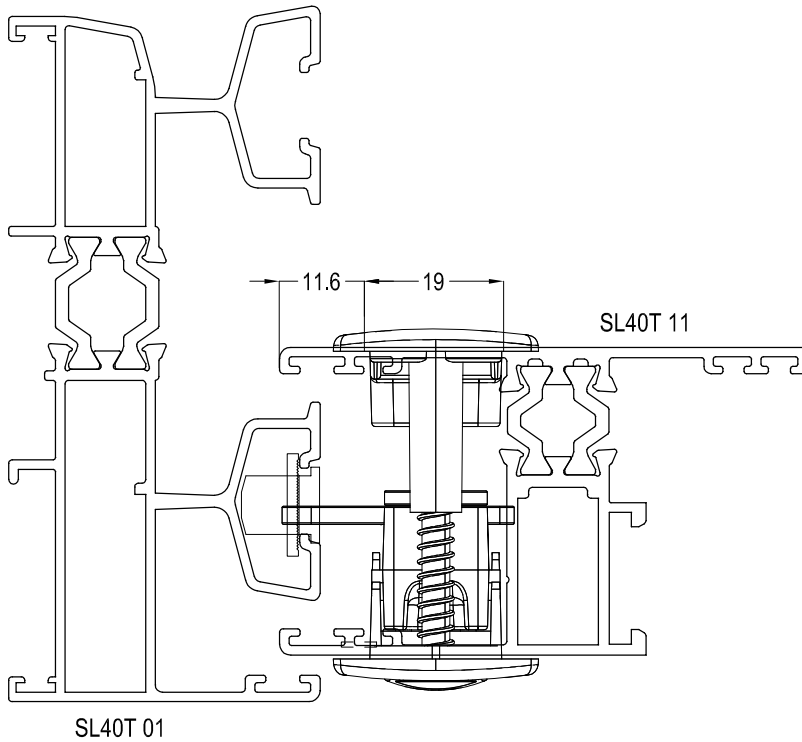
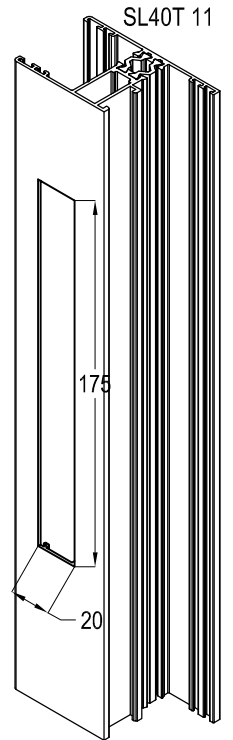
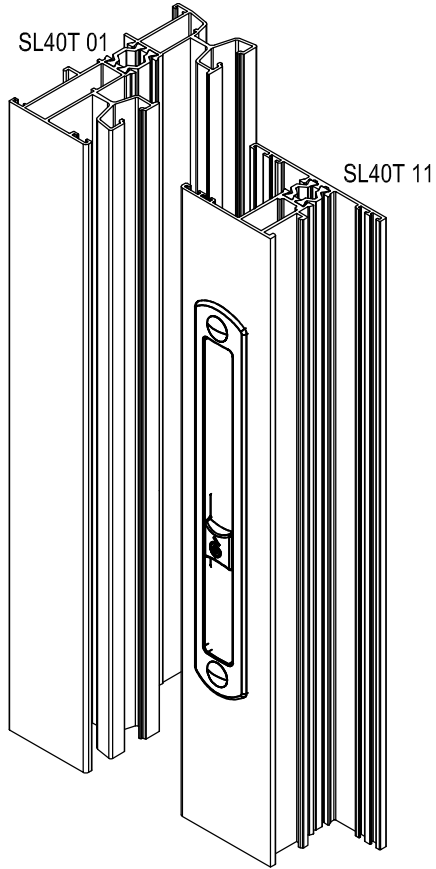
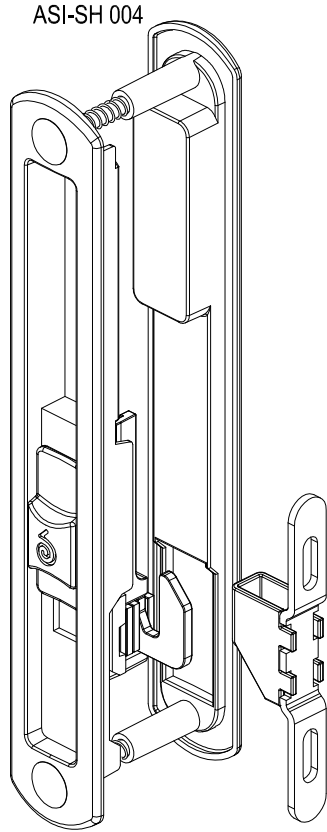

ÇEKME KOL : ASI-SH 005 / ASI-SH 006
PULL HANDLE : ASI-SH 005 / ASI-SH 006

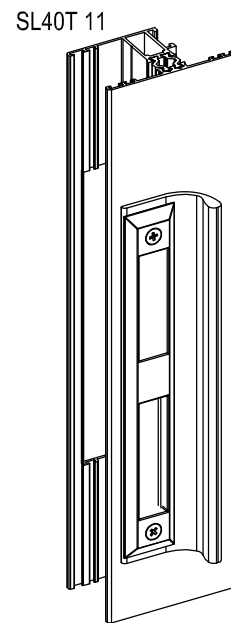
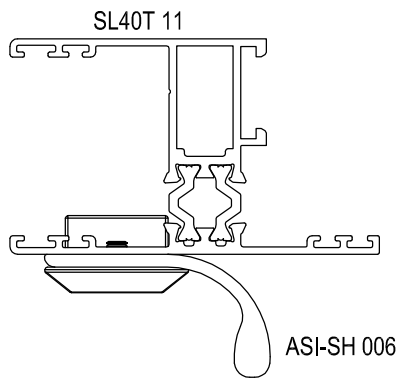
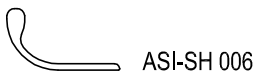
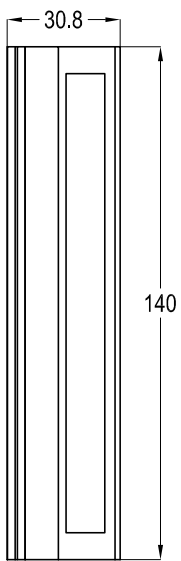
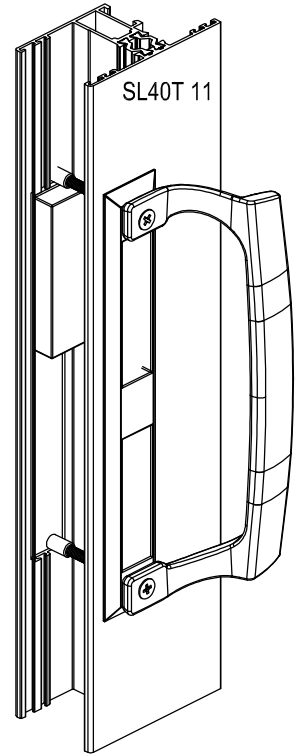
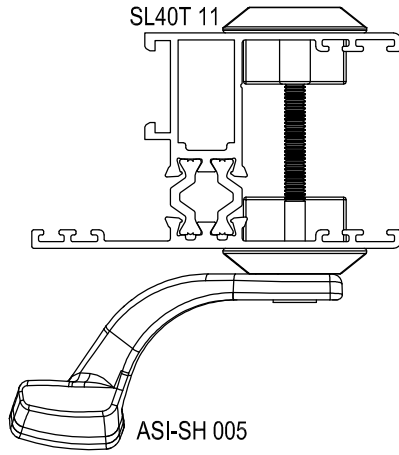
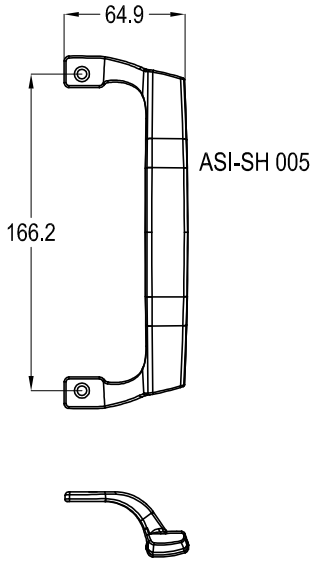

İSPANYOLET KİLİTLEME : ASI-ISP 15
MULTI POINT LOCKING : ASI-ISP 15

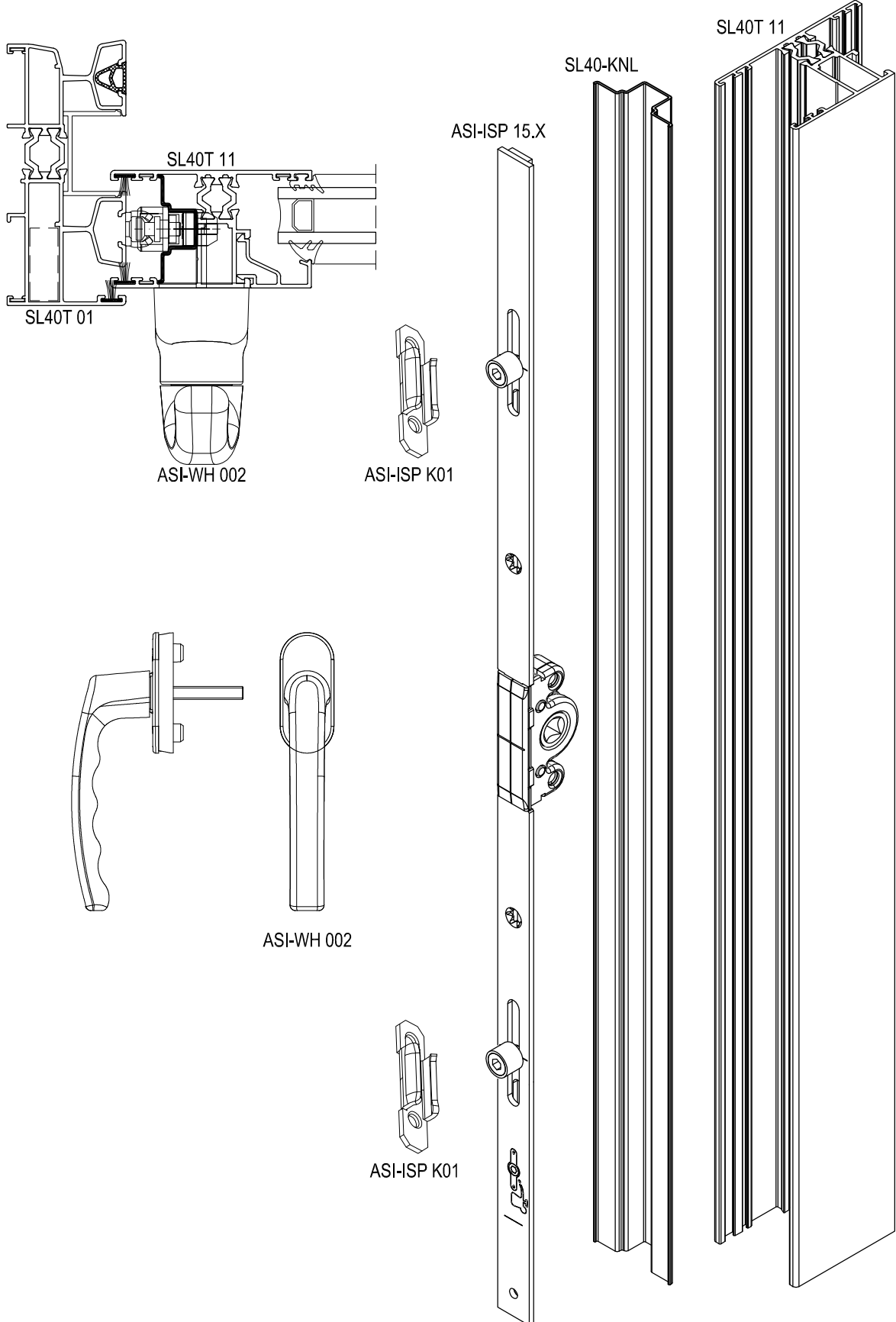

RULMAN : ASI-SR 02 / ASI-SR 02R
 ROLLER : ASI-SR 02 / ASI-SR 02R

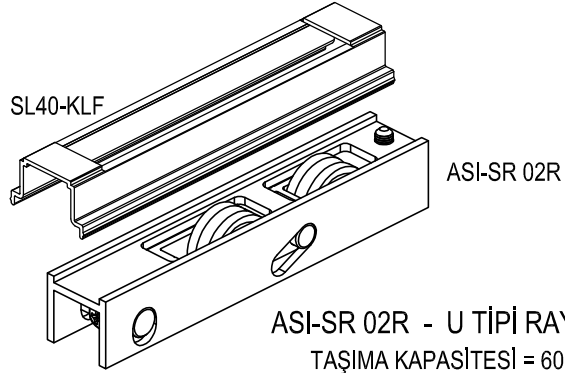
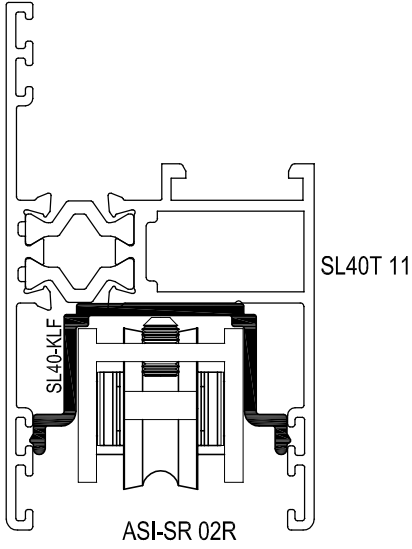

ASI-SR 02R - U TİPİ RAY İÇİN
 TAŞIMA KAPASİTESİ = 60 kg
 Carry Capacity = 60 kg
 TEK KANAT İÇİN = 120 kg
 For Per Sash = 120 kg

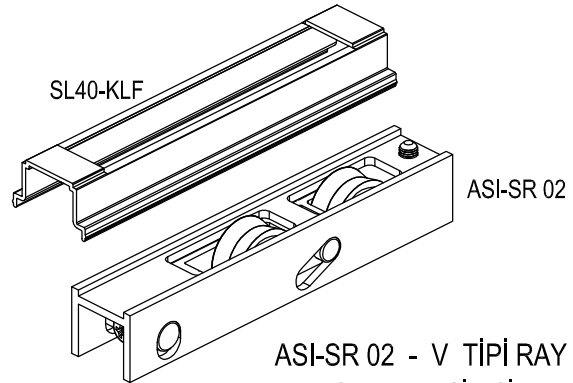
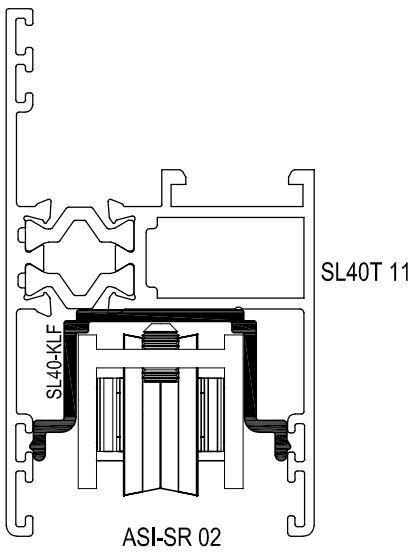
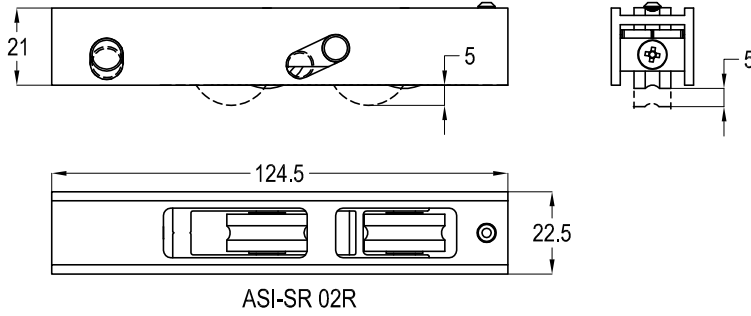

ASI-SR 02 - V TİPİ RAY İÇİN
 TAŞIMA KAPASİTESİ = 60 kg
 Carry Capacity = 60 kg
 TEK KANAT İÇİN = 120 kg
 For Per Sash = 120 kg

KANAT GÜVENLİK PLASTİĞİ : SL40-STP
ANTI LIFT DEVICE : SL40-STP

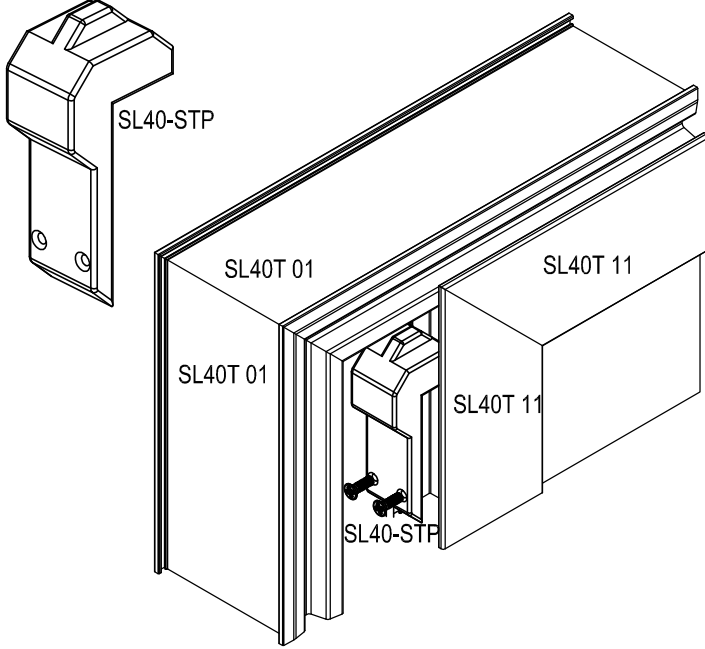

ADAPTÖR KAPAĞI : SL40-KP02
MEETING STILE CAP : SL40-KP02

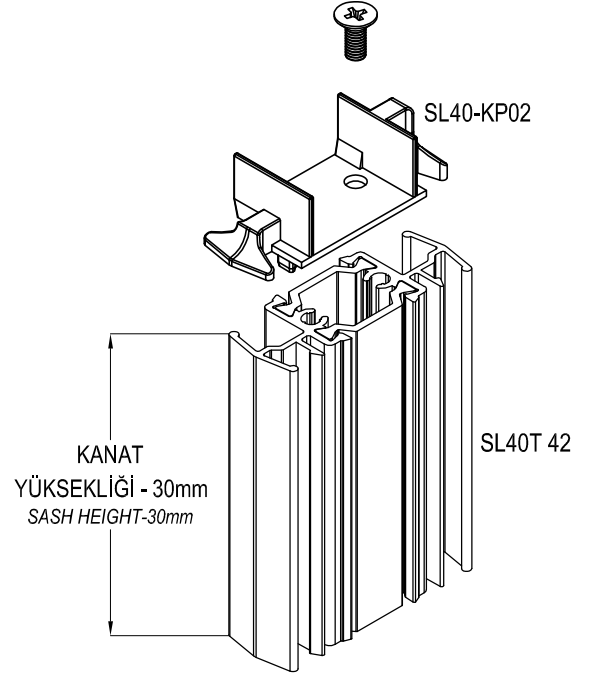

KENET KAPAĞI : SL40-KP01
INTERLOCK PROFILE CAP : SL40-KP01

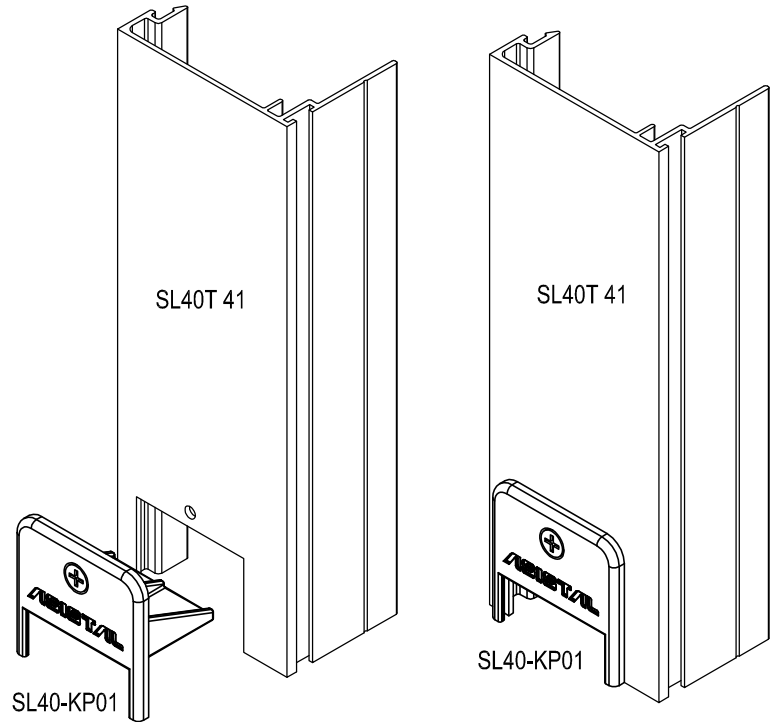
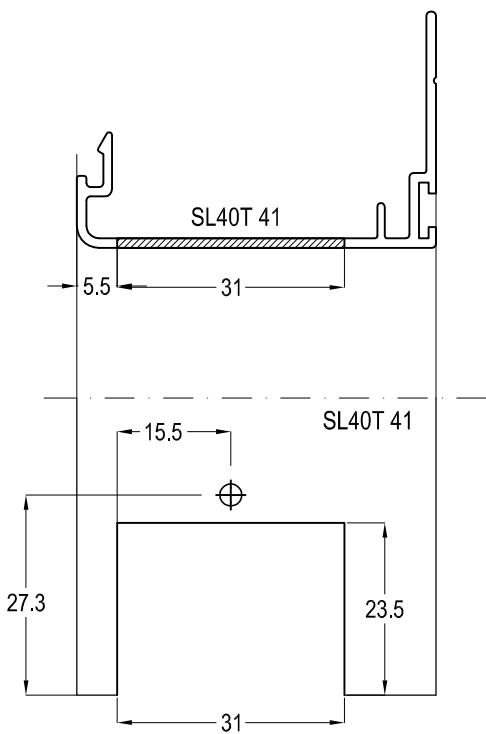

TAKVİYE KOL PROFİLİ BAĞLANTI MONTAJI ASSEMBLY FOR HANDLE PROFILE

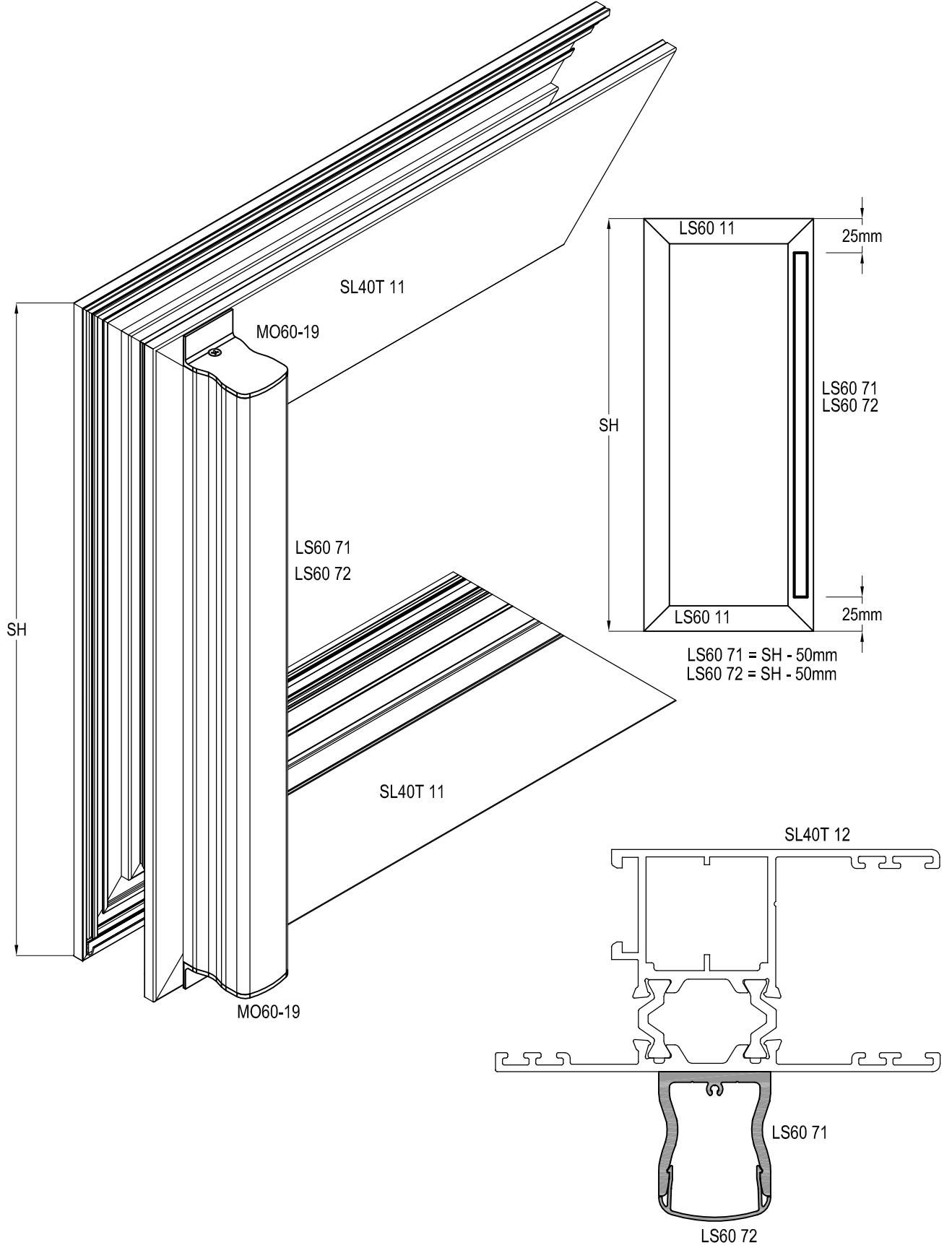

KANAT SABİTLEME MONTAJI ASSEMBLY FOR SASH FIXING

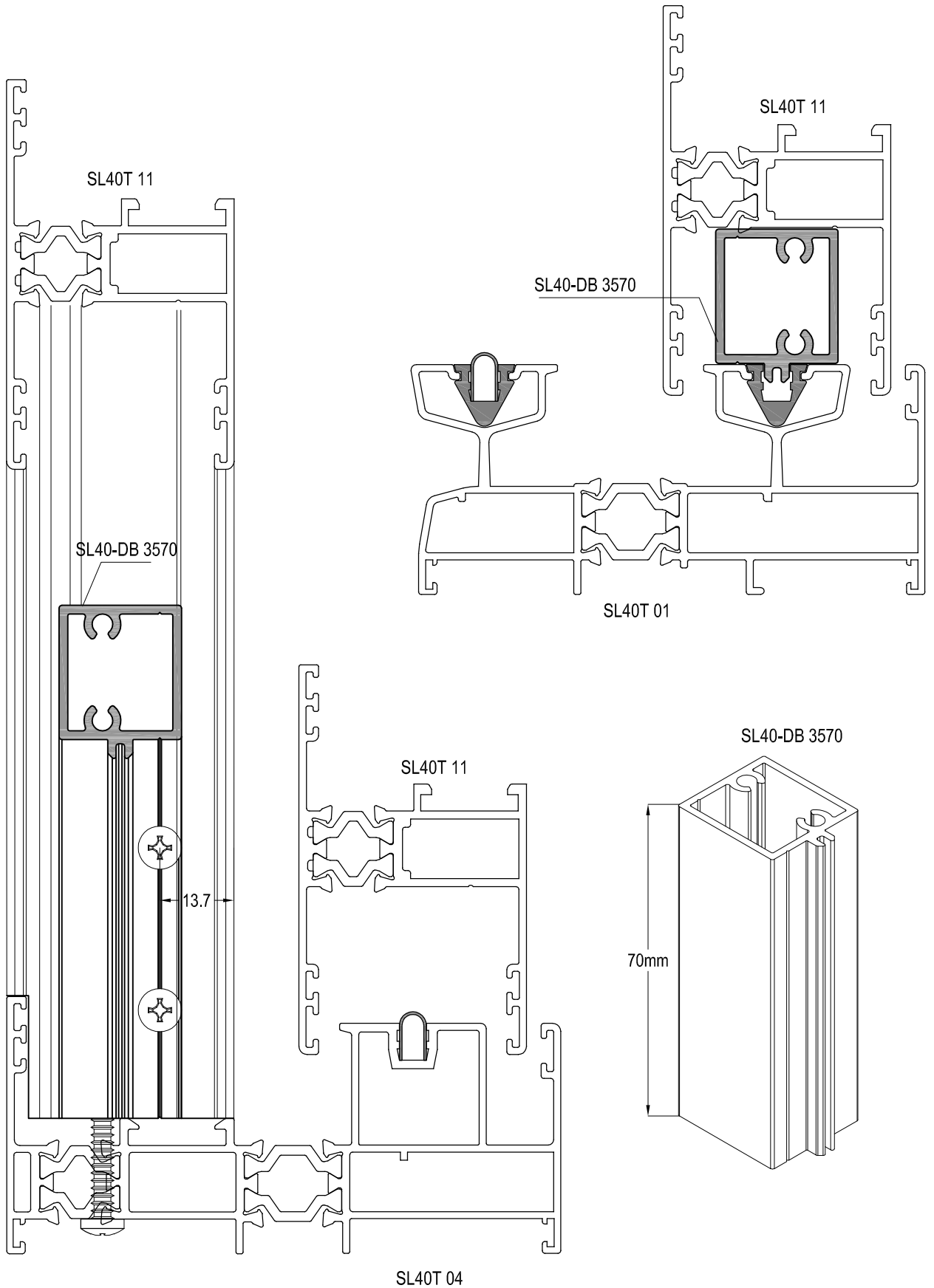

2 HAREKETLİ KANAT KESİM ÖLÇÜLERİ 2 SLIDING SASHES CUTTING SIZE

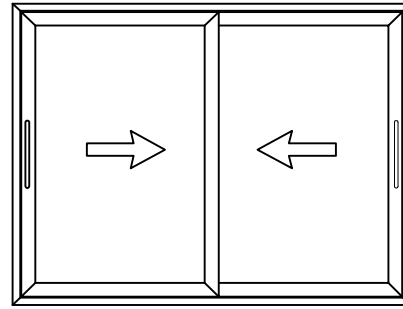
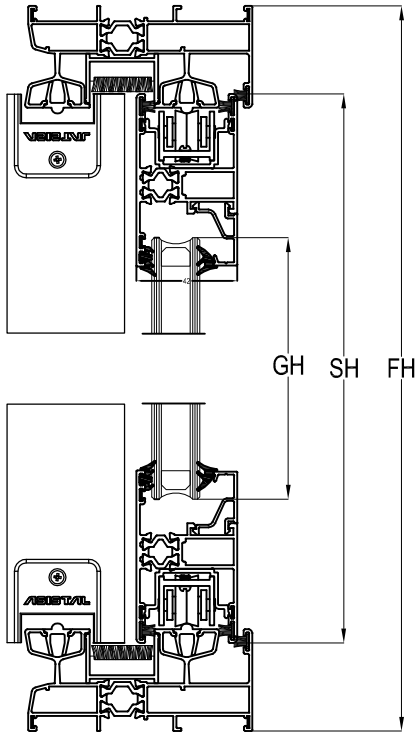
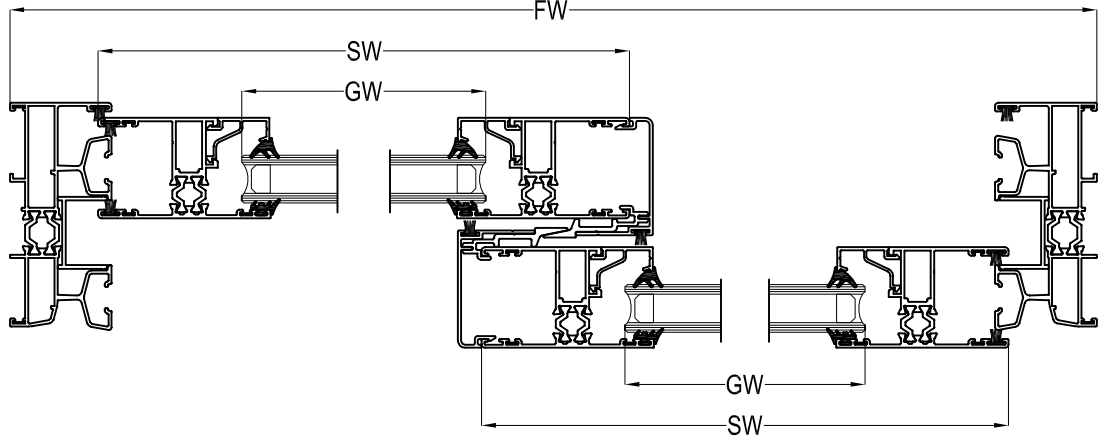

KASA PROFİLİ FRAME PROFILE	KANAT PROFİLİ SASH PROFILE	KESİM ÖLÇÜLERİ CUTTING SIZES
SL40T 01 SL40T 02	SL40T 11	SW = FW / 2 - 5,8mm GW = SW - 114mm SH = FH - 73,6mm GH = SH - 114mm SL40T 41 = SH
SL40T 01 SL40T 02	SL40T 12	SW = FW / 2 + 0,2mm GW = SW - 138mm SH = FH - 73,6mm GH = SH - 138mm SL40T 41 = SH

FW= KASA GENİŞLİĞİ / FRAME WIDTH
SW= KANAT GENİŞLİĞİ / SASH WIDTH
GW= CAM GENİŞLİĞİ / GLASS WIDTH

FH= KASA YÜKSEKLİĞİ / FRAME HEIGHT
SH= KANAT YÜKSEKLİĞİ / SASH HEIGHT
GH= CAM YÜKSEKLİĞİ / GLASS HEIGHT

3 LÜ KANAT KESİM ÖLÇÜLERİ 3 SASHES CUTTING SIZE

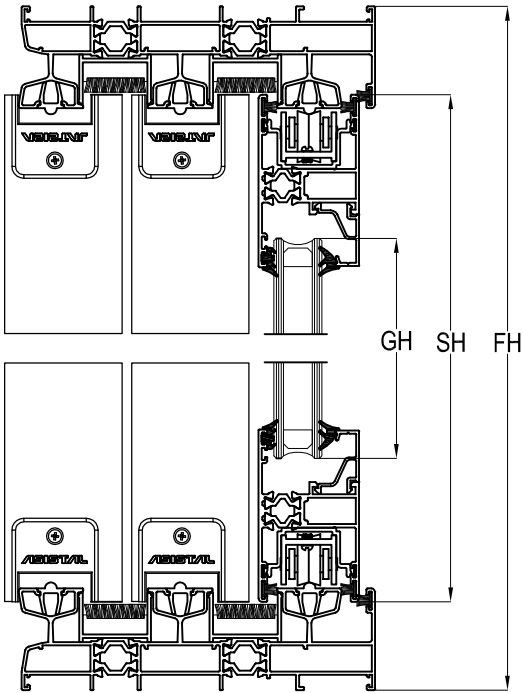
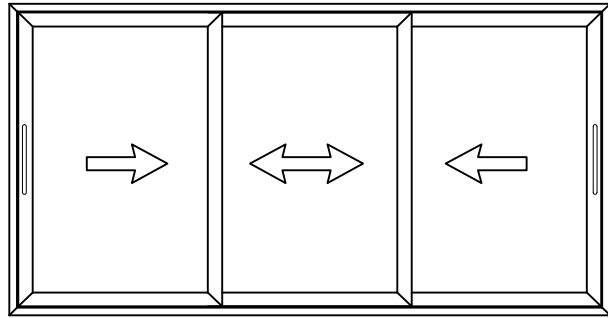
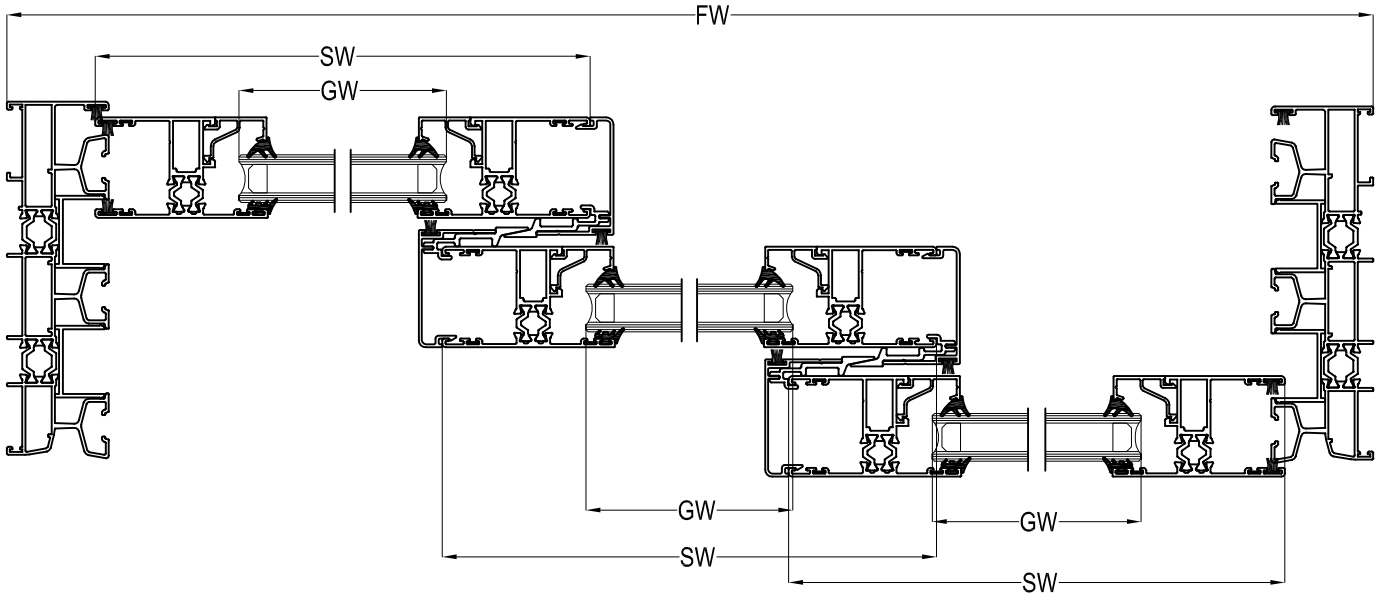

KASA PROFİLİ FRAME PROFILE	KANAT PROFİLİ SASH PROFILE	KEŞİM ÖLÇÜLERİ CUTTING SIZES
SL40T 03 SL40T 05	SL40T 11	$SW = FW / 3 + 16,7\text{mm}$ $GW = SW - 114\text{mm}$ $SH = FH - 73,6\text{mm}$ $GH = SH - 114\text{mm}$ $SL40T41 = SH$
SL40T 03 SL40T 05	SL40T 12	$SW = FW / 3 + 23,7\text{mm}$ $GW = SW - 138\text{mm}$ $SH = FH - 73,6\text{mm}$ $GH = SH - 138\text{mm}$ $SL40T 41 = SH$

FW= KASA GENİŞLİĞİ / FRAME WIDTH
 SW= KANAT GENİŞLİĞİ / SASH WIDTH
 GW= CAM GENİŞLİĞİ / GLASS WIDTH

FH= KASA YÜKSEKLİĞİ / FRAME HEIGHT
 SH= KANAT YÜKSEKLİĞİ / SASH HEIGHT
 GH= CAM YÜKSEKLİĞİ / GLASS HEIGHT

4 LÜ KANAT KESİM ÖLÇÜLERİ 4 SASHES CUTTING SIZE

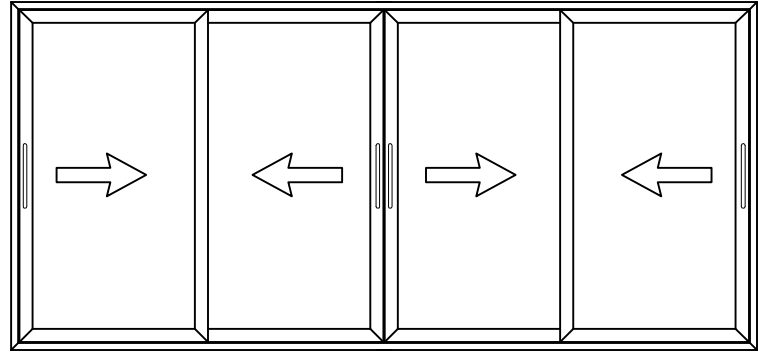
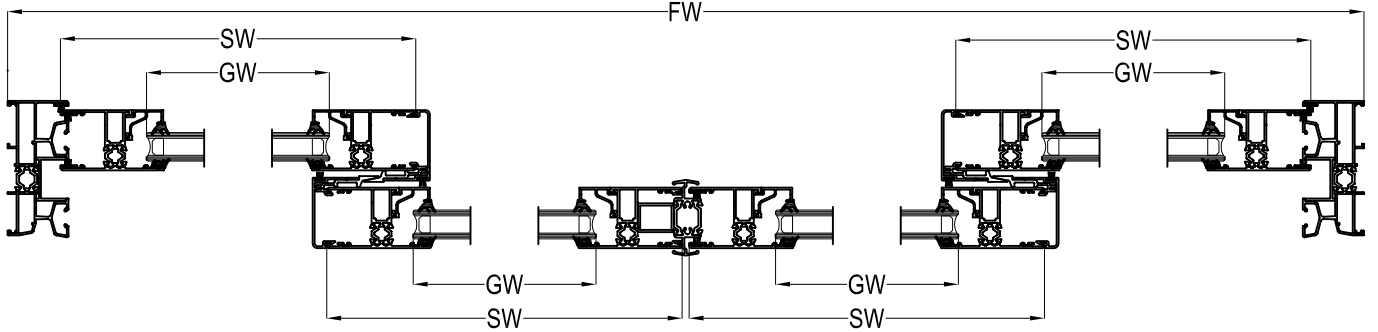

ADAPTÖR PROFİLİ
SL40T 42 = SH - 30mm

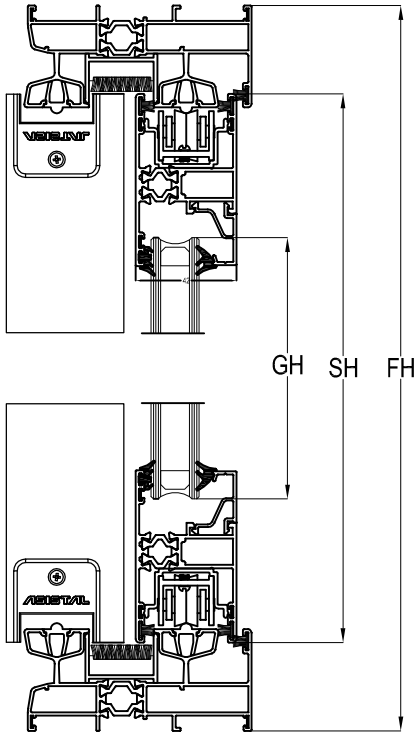

KASA PROFİLİ FRAME PROFILE	KANAT PROFİLİ SASH PROFILE	KESİM ÖLÇÜLERİ CUTTING SIZES
SL40T 01 SL40T 02	SL40T 11	SW = FW / 4 + 11,2mm GW = SW - 114mm SH = FH - 73,6mm GH = SH - 114mm
SL40T 01 SL40T 02	SL40T 12	SL40T 41 = SH SW = FW / 34 + 17,2mm GW = SW - 138mm SH = FH - 73,6mm GH = SH - 138mm
		SL40T 41 = SH

FW= KASA GENİŞLİĞİ / FRAME WIDTH
SW= KANAT GENİŞLİĞİ / SASH WIDTH
GW= CAM GENİŞLİĞİ / GLASS WIDTH

FH= KASA YÜKSEKLİĞİ / FRAME HEIGHT
SH= KANAT YÜKSEKLİĞİ / SASH HEIGHT
GH= CAM YÜKSEKLİĞİ / GLASS HEIGHT

SABİTLİ KASADA 1 HAREKETLİ KANAT KESİM ÖLÇÜLERİ 1 SLIDING SASH IN FIXED FRAME CUTTING SIZE

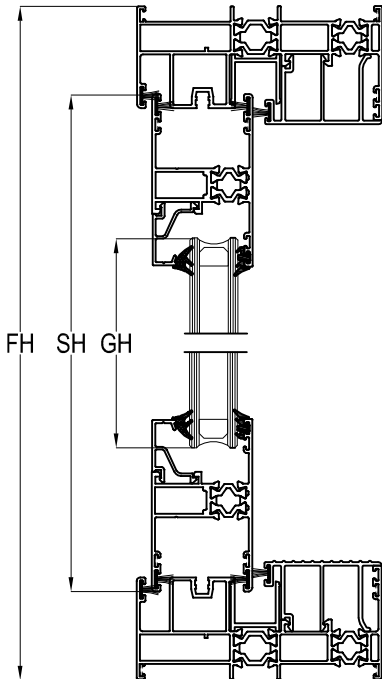
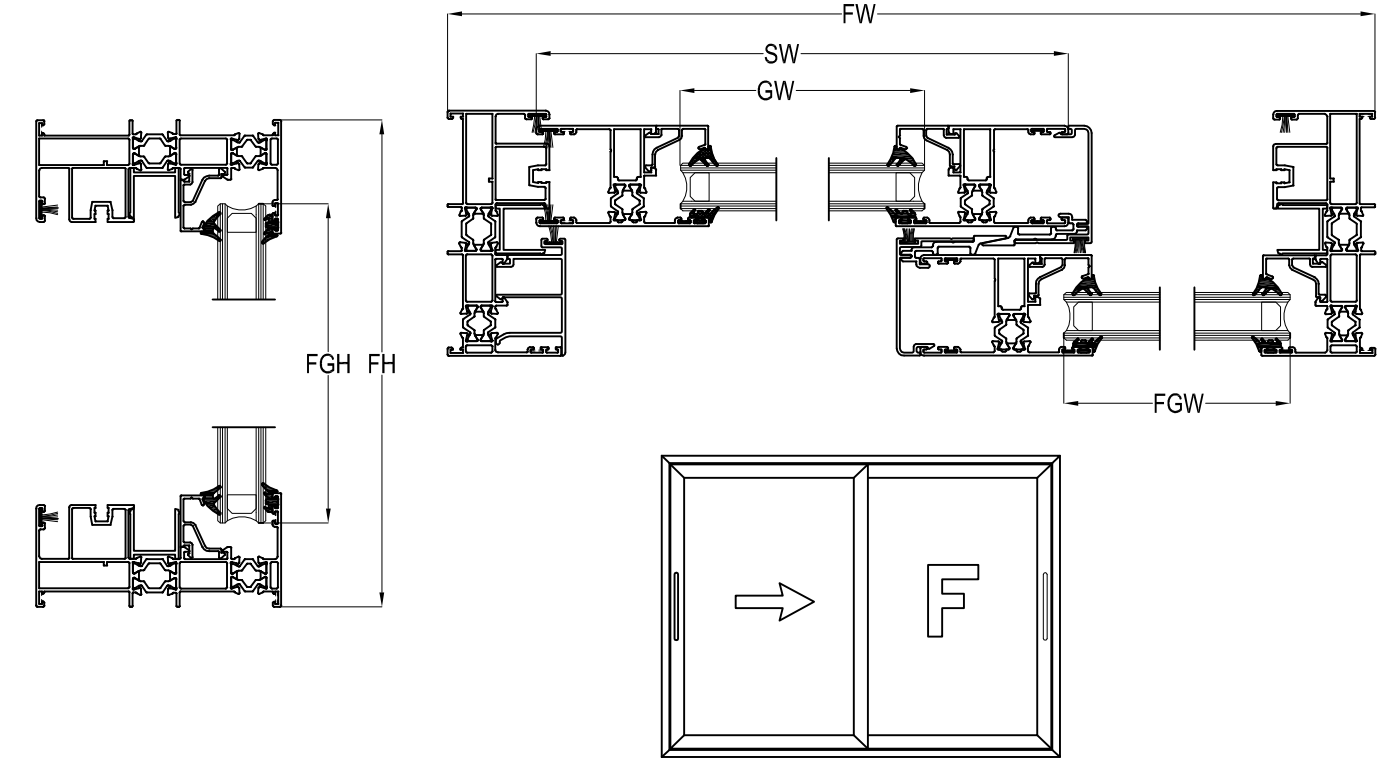

KASA PROFİLİ FRAME PROFILE	KANAT PROFİLİ SASH PROFILE	KESİM ÖLÇÜLERİ CUTTING SIZES
SL40T 04	SL40T 11	$SW = FW / 2 + 25,1mm$ $GW = SW - 114mm$ $FGW = FW / 2 - 89mm$ $SH = FH - 73,6mm$ $GH = SH - 114mm$ $SL40T 41 = SH$
SL40T 04	SL40T 12	$SW = FW / 2 + 37mm$ $GW = SW - 138mm$ $FGW = FW / 2 - 100,8mm$ $SH = FH - 73,6mm$ $GH = SH - 138mm$ $SL40T 41 = SH$

FW= KASA GENİŞLİĞİ / FRAME WIDTH
 SW= KANAT GENİŞLİĞİ / SASH WIDTH
 GW= CAM GENİŞLİĞİ / GLASS WIDTH
 FGW= CAM GENİŞLİĞİ / GLASS WIDTH

FH= KASA YÜKSEKLİĞİ / FRAME HEIGHT
 SH= KANAT YÜKSEKLİĞİ / SASH HEIGHT
 GH= CAM YÜKSEKLİĞİ / GLASS HEIGHT
 FGH= CAM YÜKSEKLİĞİ / GLASS HEIGHT

Fabrika / Factory

Adres: Organize San. Bölg.
No: 2, Cad.2 Kırklareli / Türkiye
Tel : 0288 263 44 15
Fax : 0288 263 43 36

Çorlu – Genel Merkez / Head Office

Adres: Hatip Mah.
Ali Osman Çelebi Bulvarı No:54
Çorlu / Tekirdağ / Türkiye
Tel : 0282 652 50 96
Fax : 0282 652 56 76

İstanbul- Bölge Müdürlüğü / District Office

Adres: Prof.Dr.Nevzat Pisak Cad.
Doğu Sanayi Sitesi 8.Blok No:3
Yenibosna / İstanbul / Türkiye
Tel : 0212 654 65 23 / 0212 654 65 24
Fax : 0212 654 65 26

İzmir – Ege Bölge Müdürlüğü / District Office

Adres: 1561 Sok. No:50
Çınarlı / İzmir / Türkiye
Tel : 0232 461 93 14 / 461 60 63
Fax : 0232 461 84 03

Sofya Ofis / Sofia Office

A: 38 Kapitan Dimitar Spisarevski Street
Res.w. Druzhba 1,
Sofia 1592 Bulgaria (Bulgaristan)
Tel : 00359 2 444 00 62
00359 889 170 062
E-mail : office@asistal.bg